

(-7901)

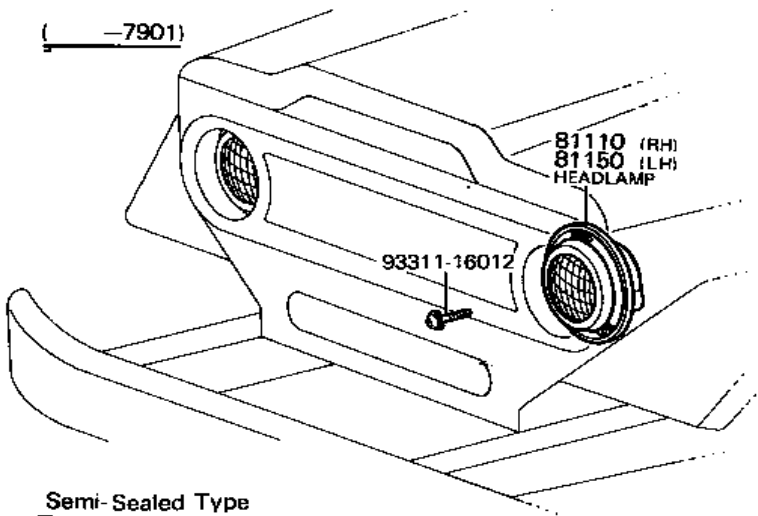

(7901-)

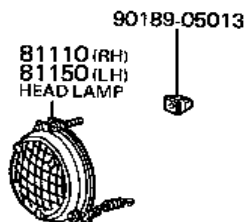

Semi-Sealed Type

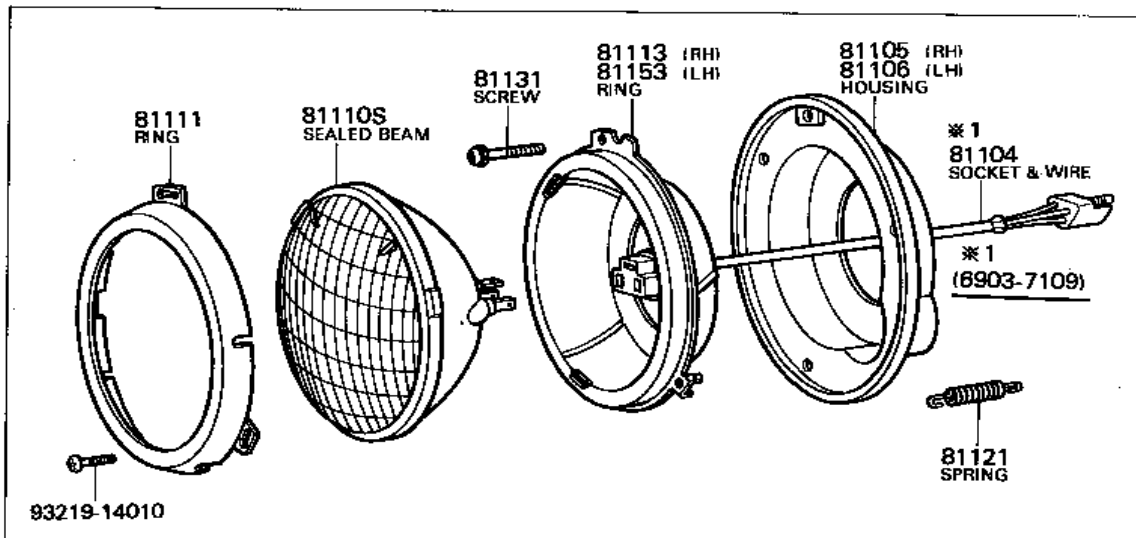
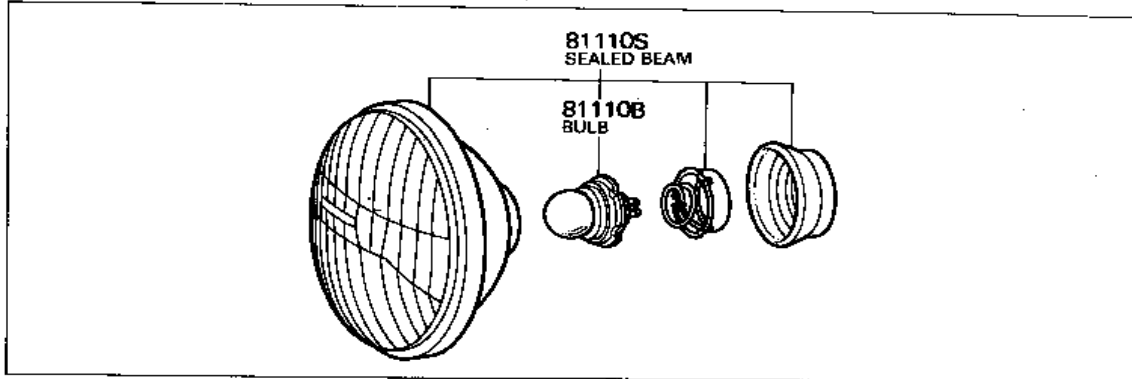

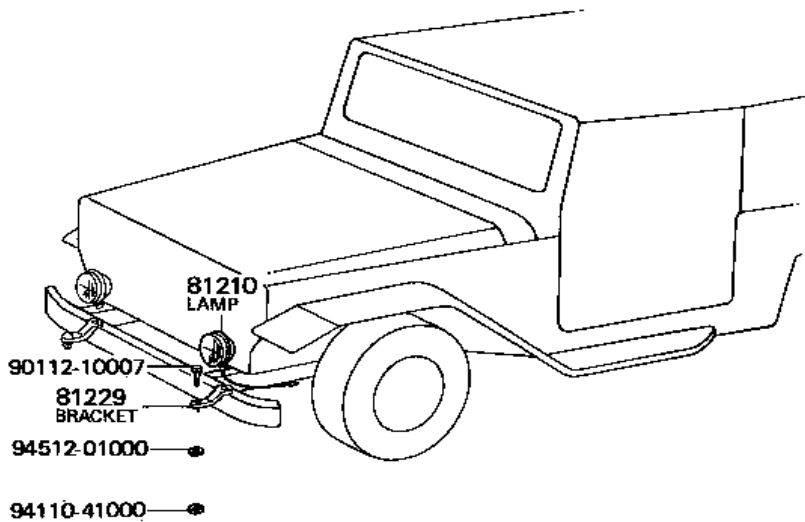

93219-66012

94521-00600

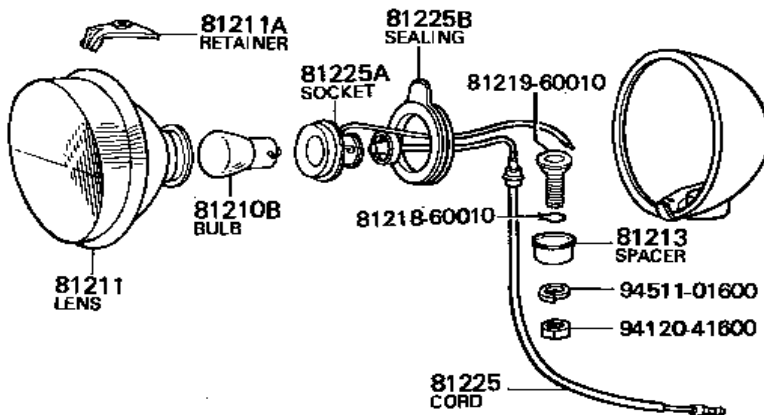

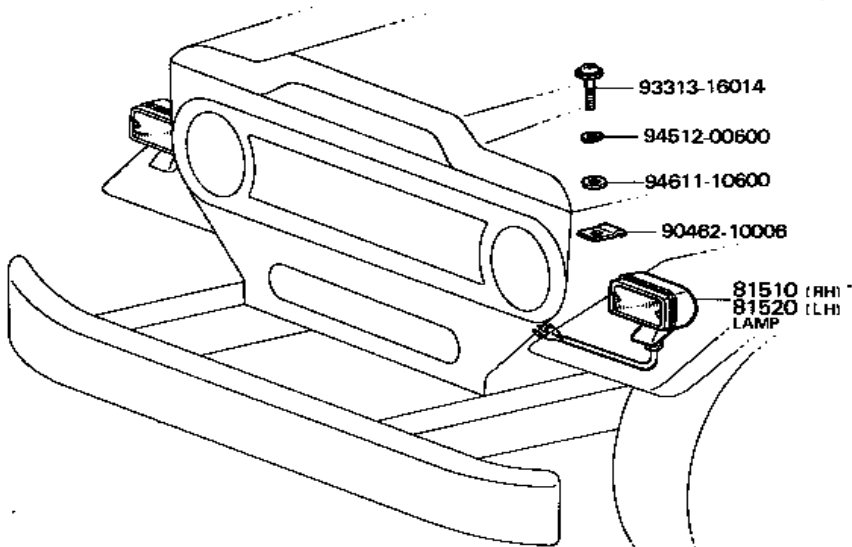

Spec	①	②
Domestic	Turn & Clearance 12V 23/8W	Parking 12V 3.4W
Export	⌈	—

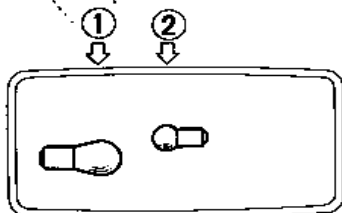

ⓓ 国内用
For Domestic

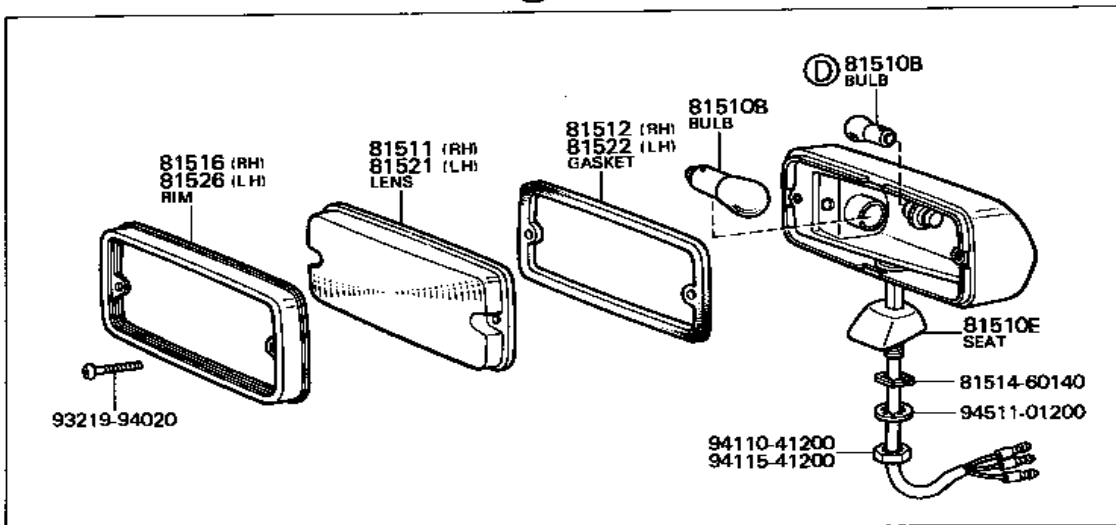

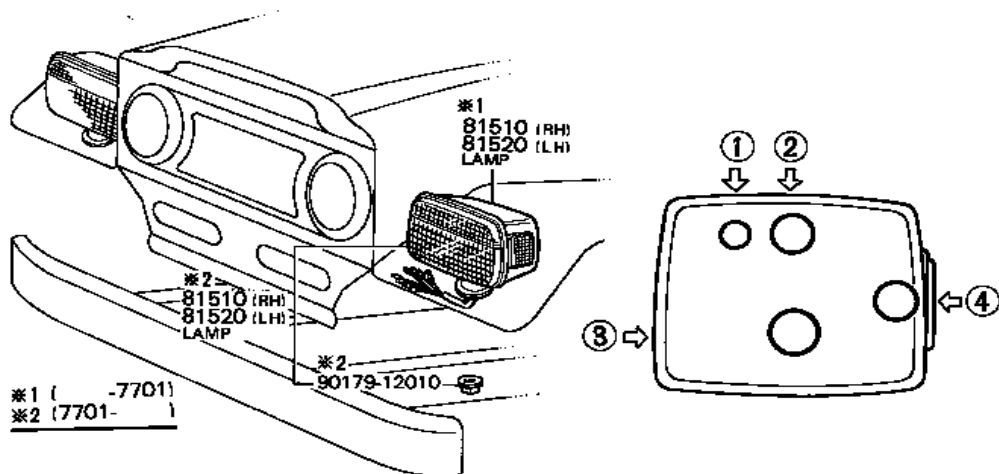

Spec.	No.	①	②	③	④
FJ4# 56 Domestic (7709-)		Parking 12V 3.4W	Clearance 12V 8W	Turn (Front) 12V 23W	Turn (Side) 12V 8W
		—	Clearance 12V 5W	↑	↑
12V System Export		—	Clearance 12V 5W	Turn (Front) 12V 21W	Turn (Side) 12V 5W
BJ4# Domestic (7709-)		Parking 24V 3W	Clearance 24V 12W	Turn (Front) 24V 25W	Turn (Side) 24V 12W
		—	Clearance 24V 5W	↑	↑
24V System Export	exl Eur.	—	Clearance 24V 12W	Turn (Front) 24V 25W	Turn (Side) 24V 12W
	Eur.	—	Clearance 24V 5W	Turn (Front) 24V 21W	Turn (Side) 24V 5W
(7709-)		—	↑	↑	↑

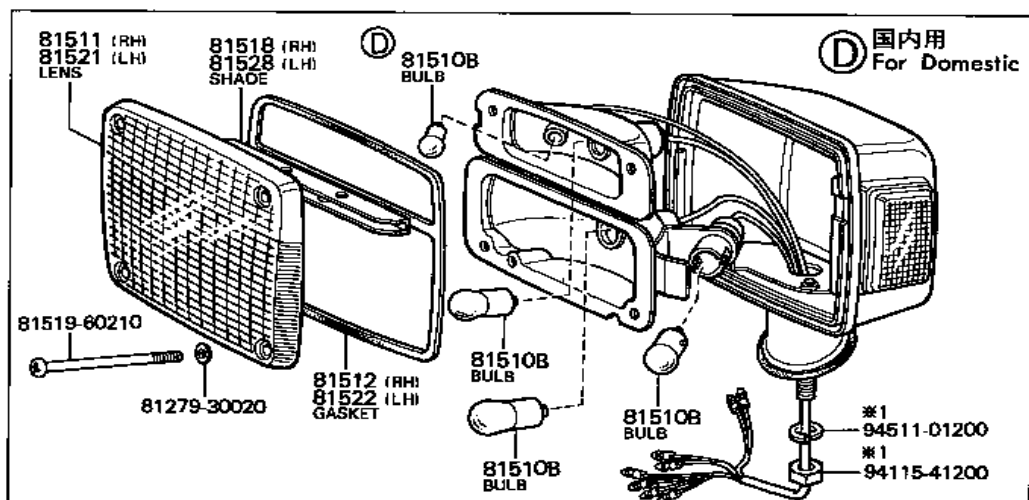

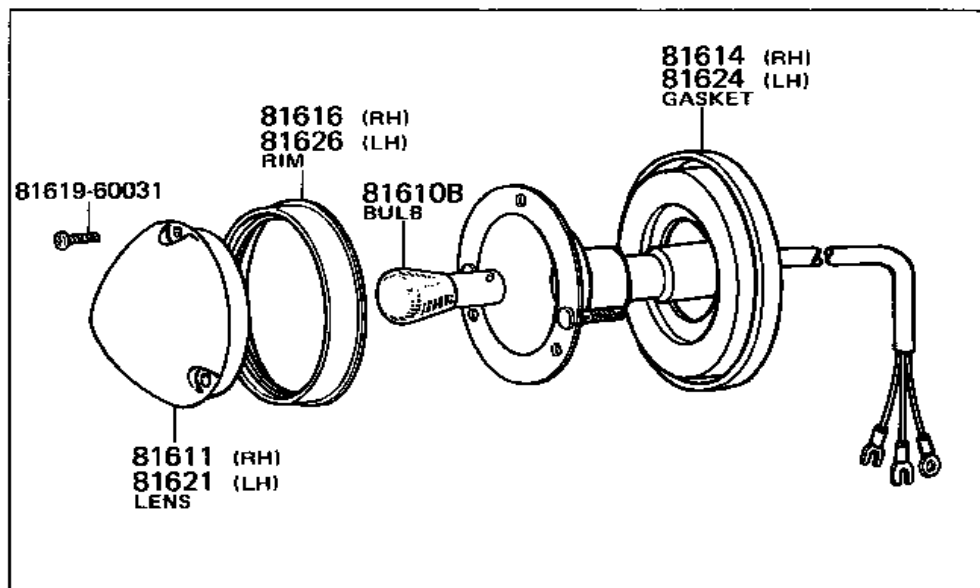
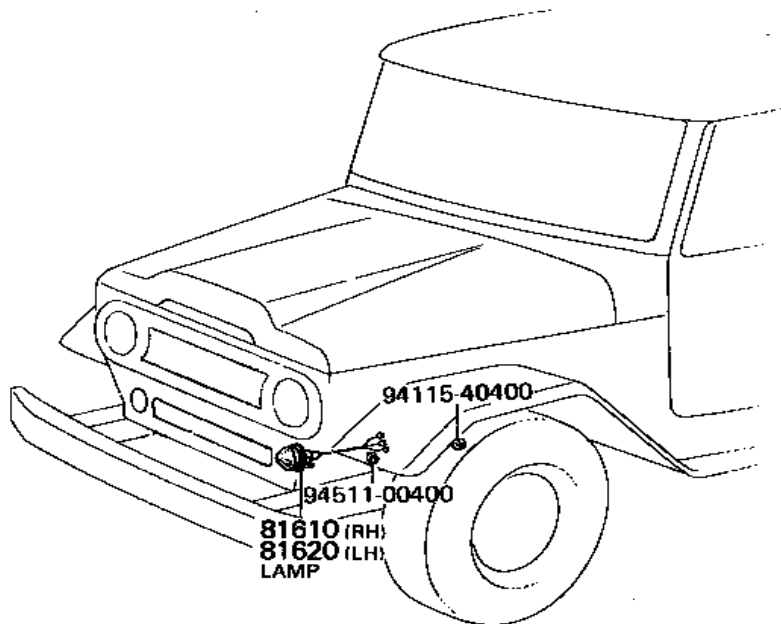

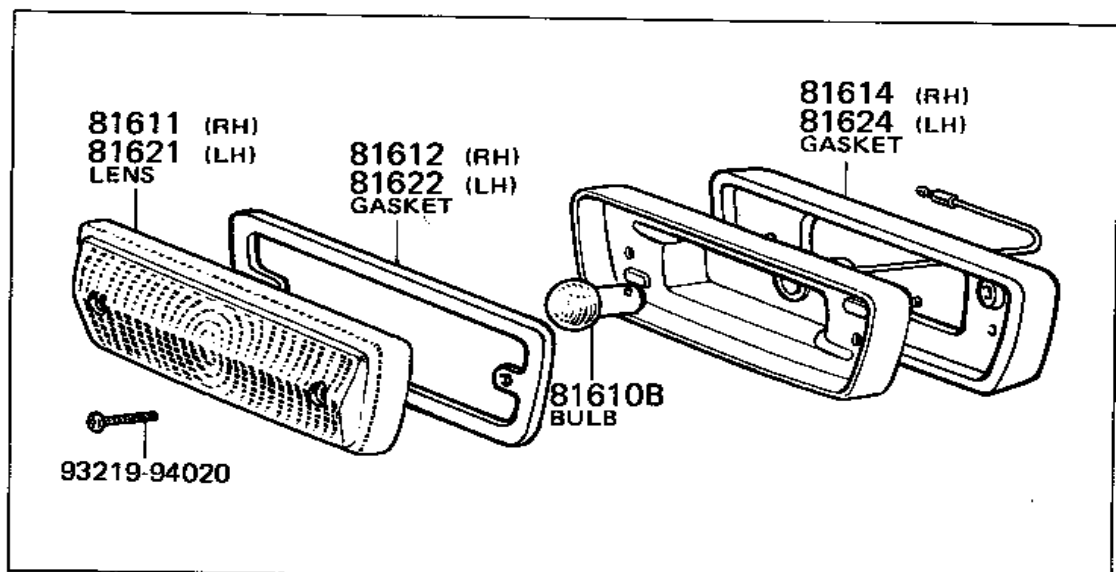
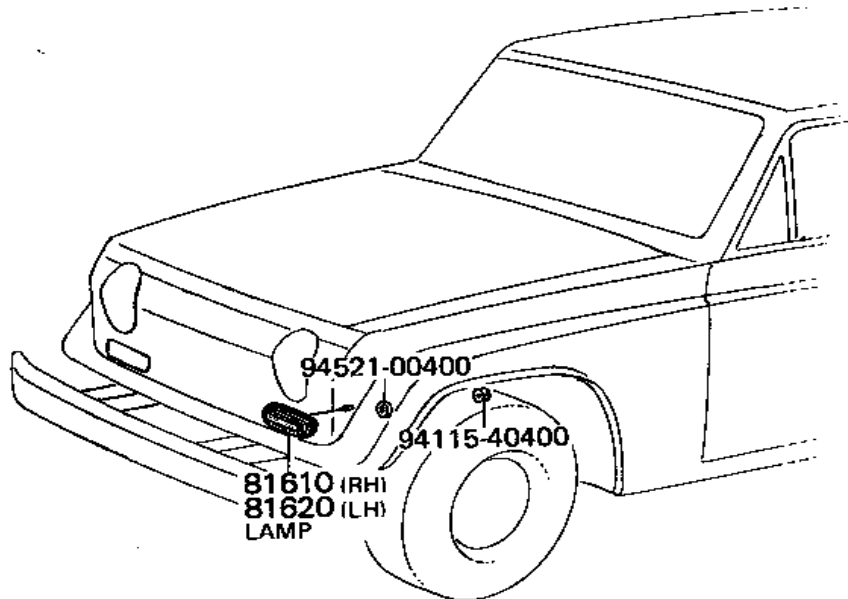

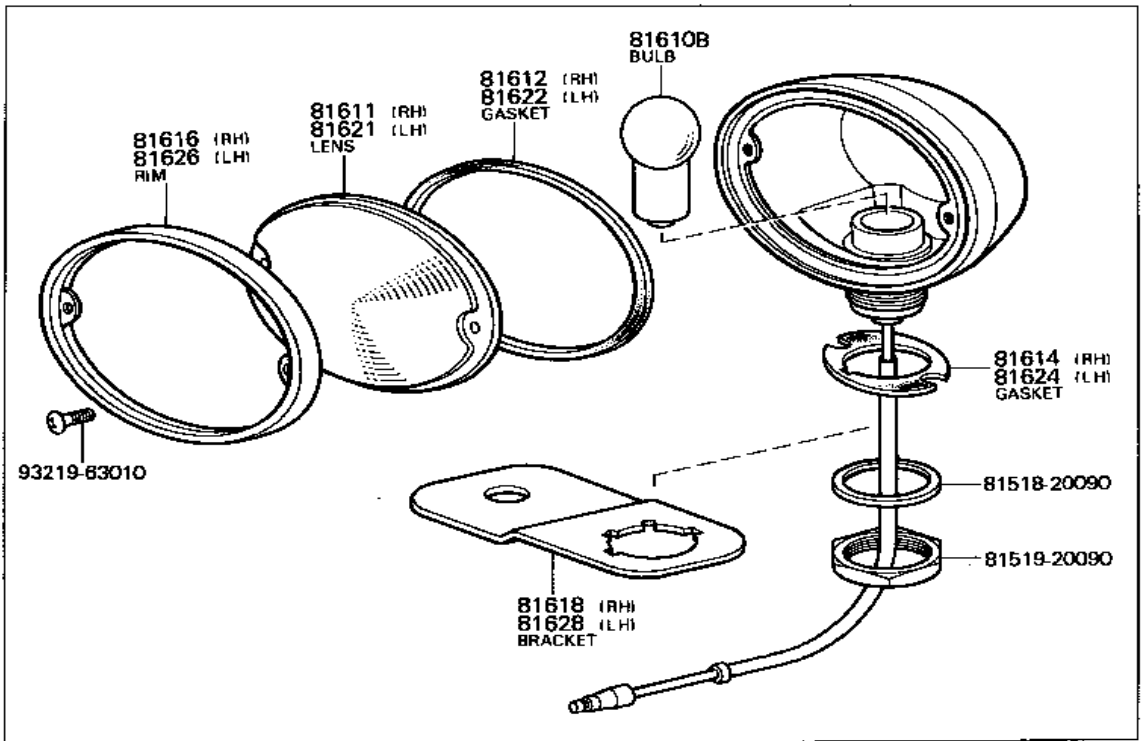
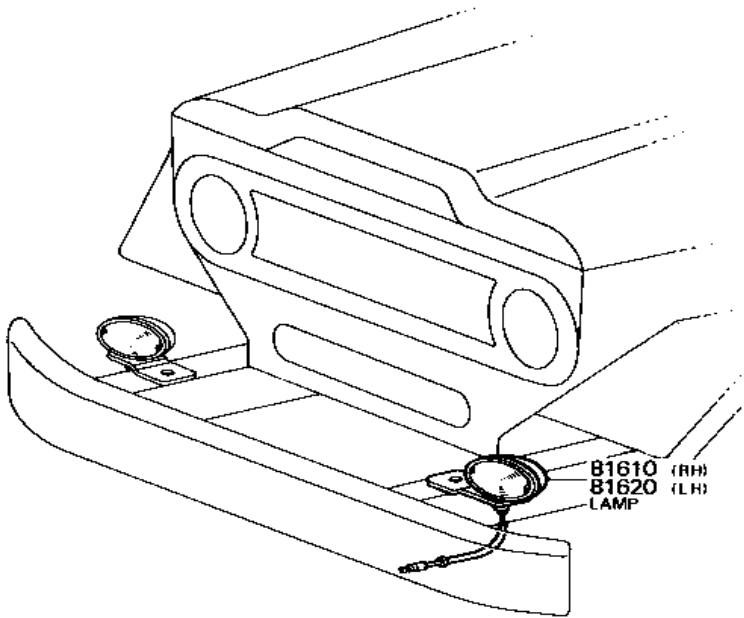

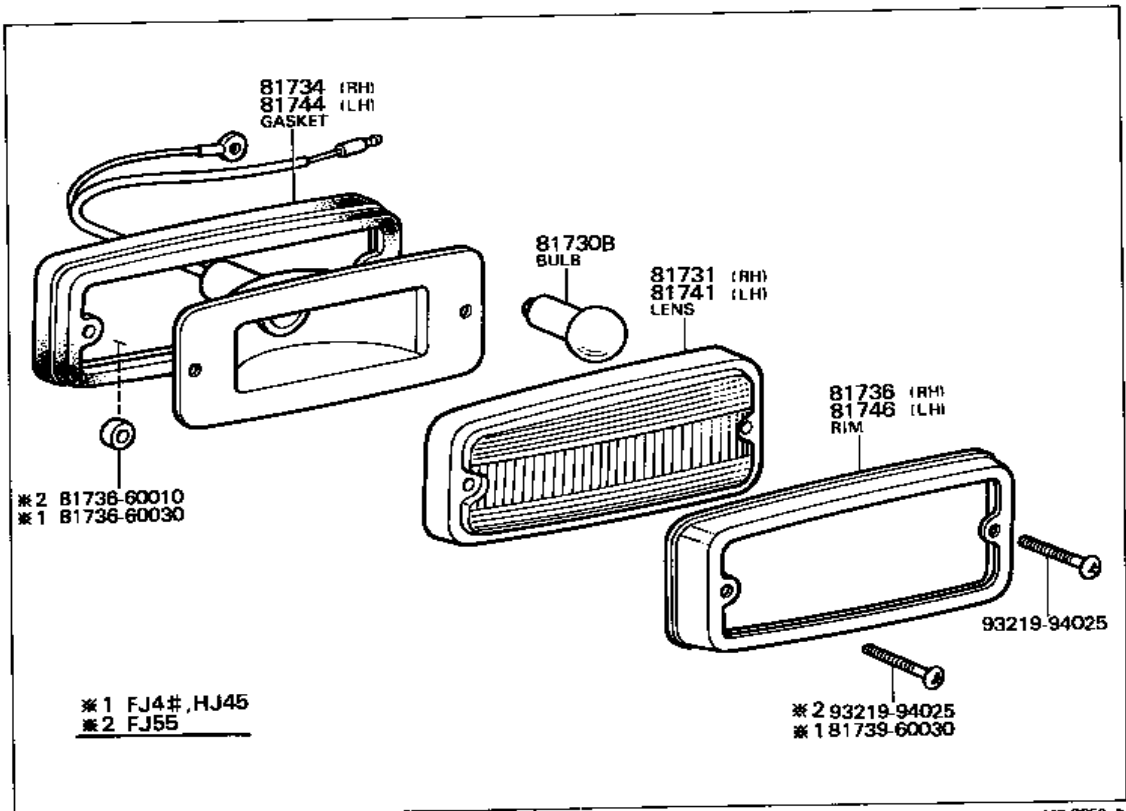
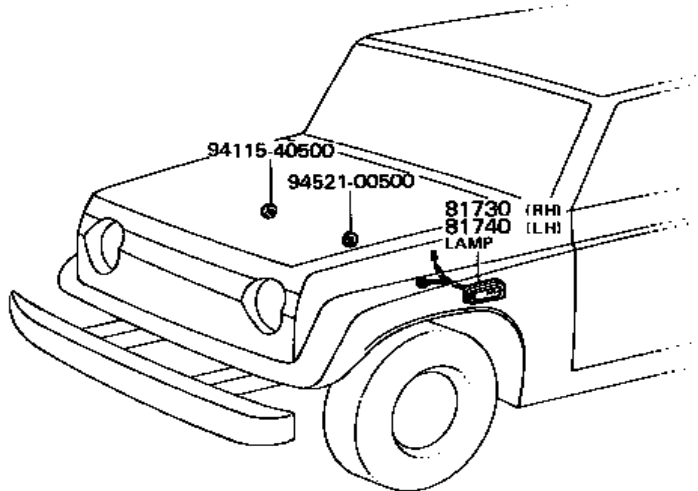

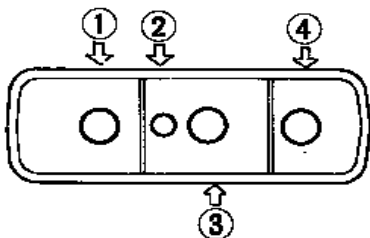
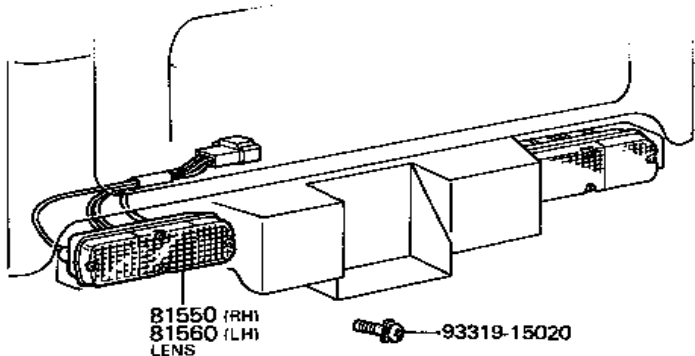

Spec.		NO.	①	②	③	④
12V用 12V System	Domestic		Turn 12V 23W	Parking 12V 3.4W	Stop & Tail 12V 23/8W	Back 12V 23W
	Export		Turn 12V 21W	—	Stop & Tail 12V 21/5W	Back 12V 21W
24V用 24V System	Domestic		Turn 24V 25W	Parking 24V 3W	Stop & Tail 24V 25/10W	Back 24V 25W
	(7709-)		Turn 24V 25W	—	Stop & Tail 24V 21/5W	Back 24V 25W
	Export		Turn 24V 21W	—	Stop & Tail 24V 21/5W	Back 24V 21W

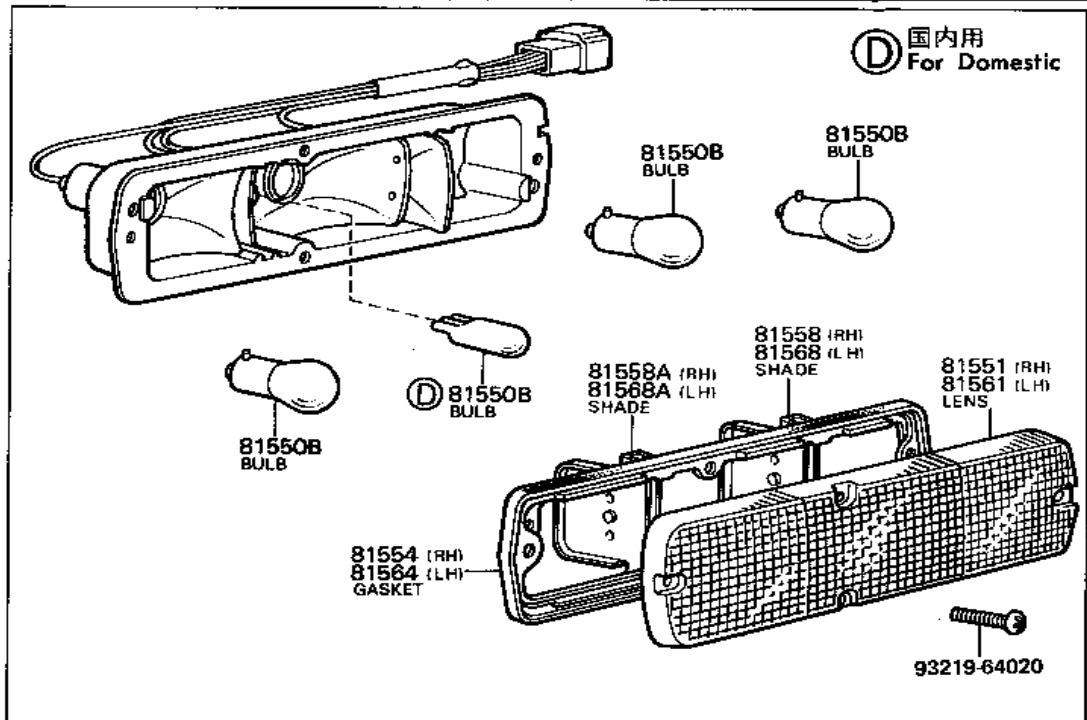

FJ40,42,43

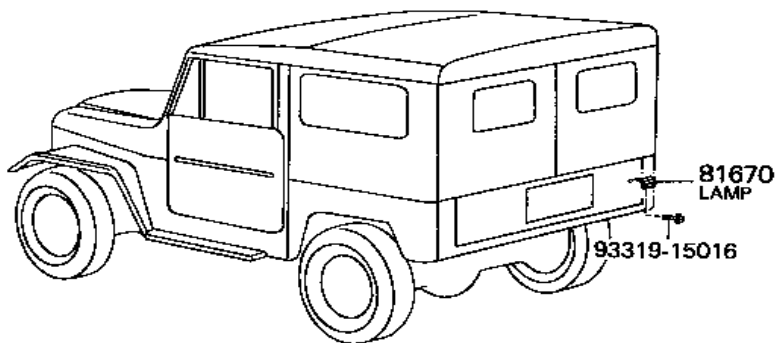

FJ55

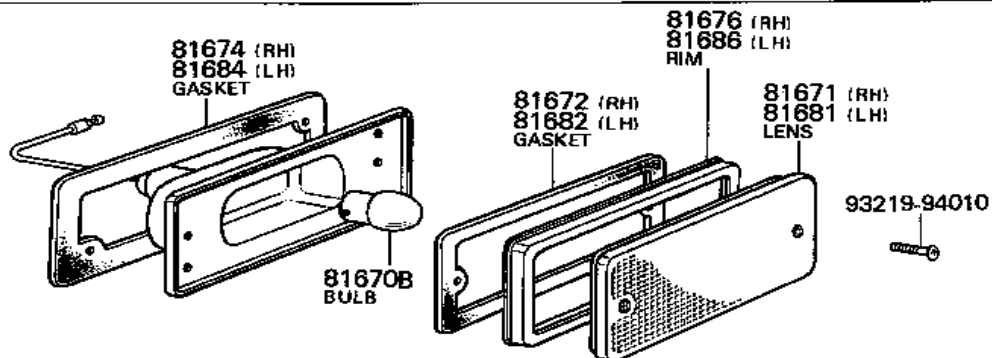
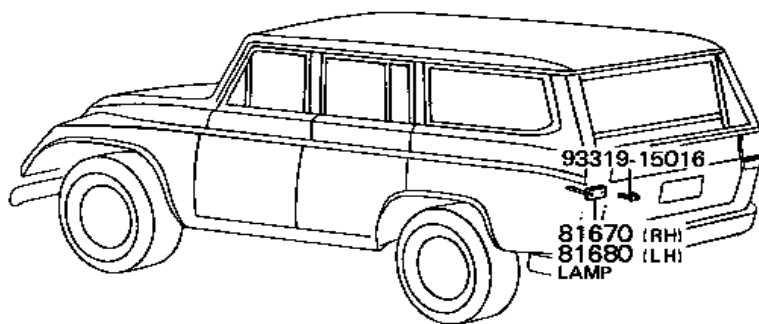

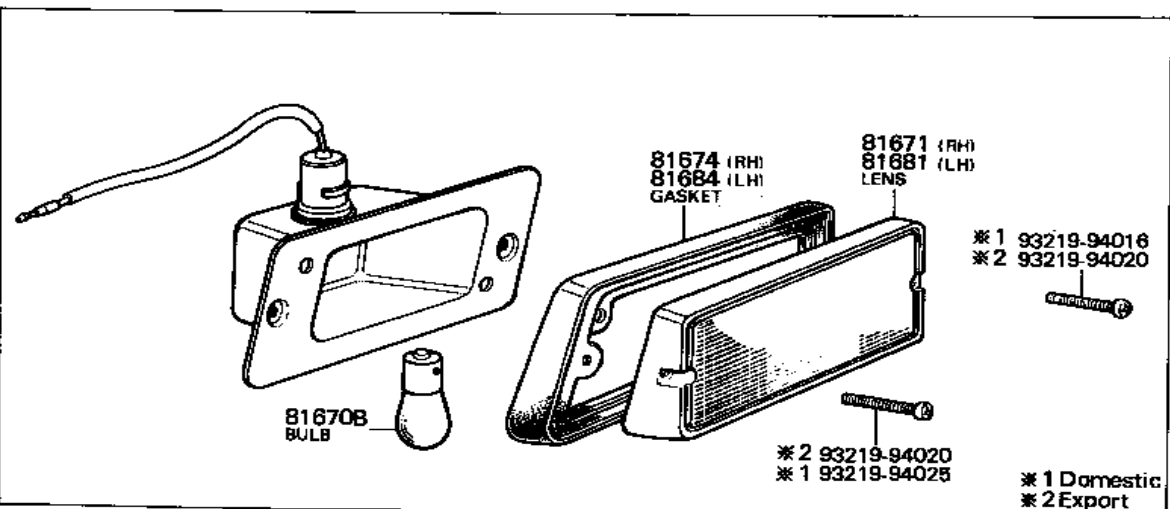
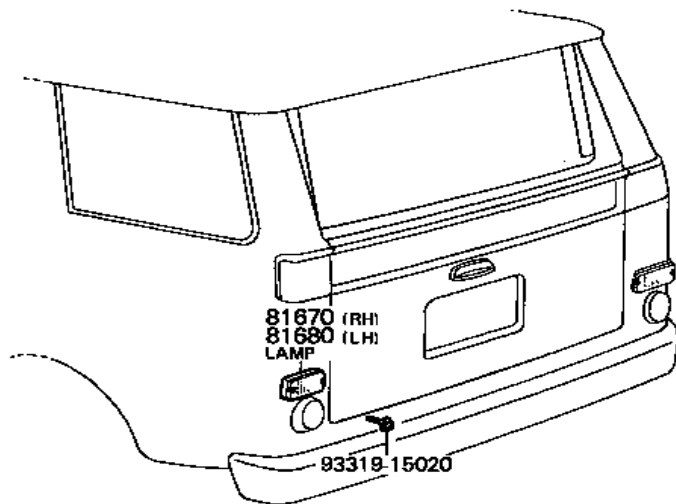

FJ40,43.. Export. FJ55.. EUR
BJ4 #.. -EUR(7402-7405)

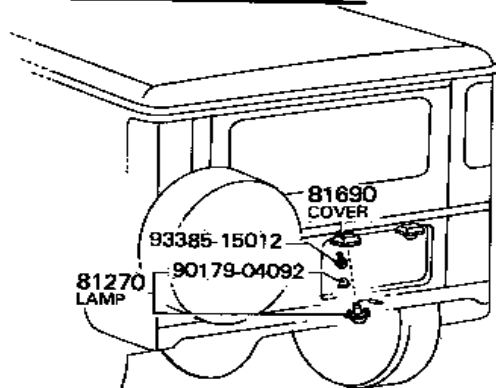

FJ40,43. Domestic
BJ4 #.. EUR(7407-7405), BJ4 #(7405-

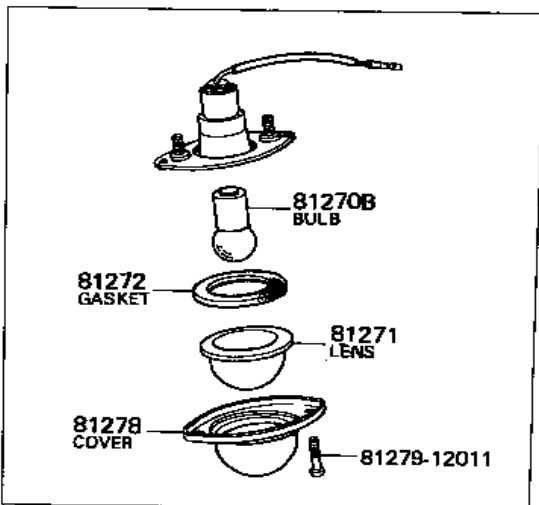
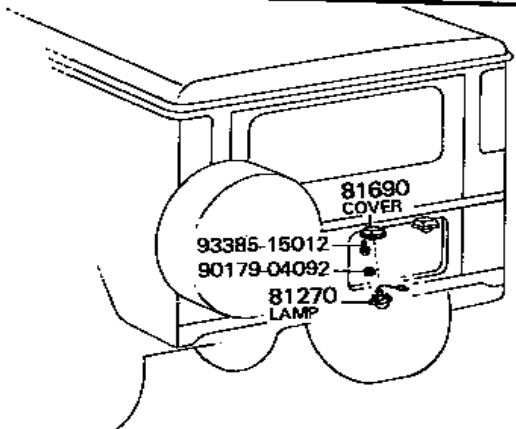

V,TP

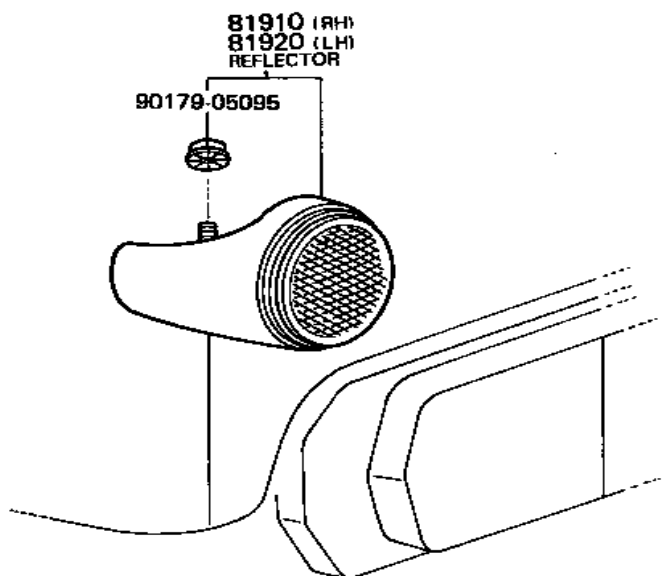

PIC

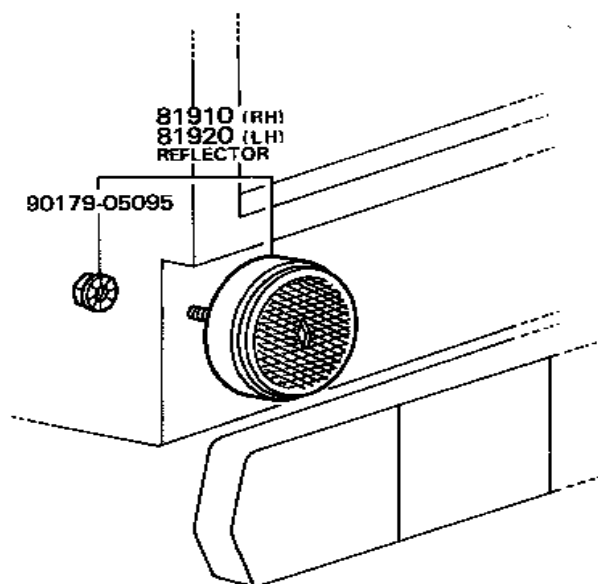

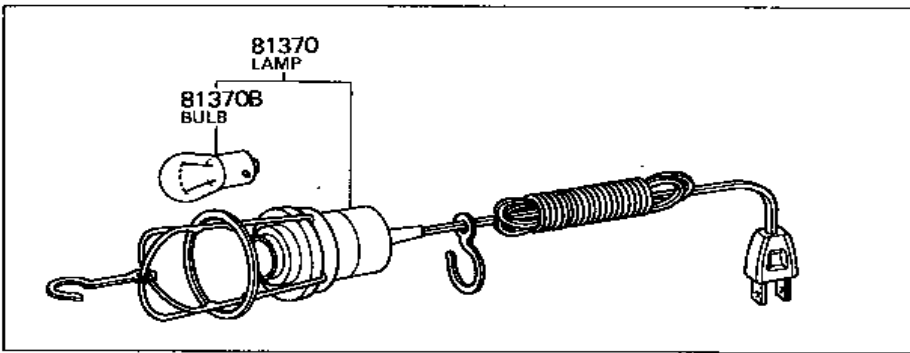

FJ5 #

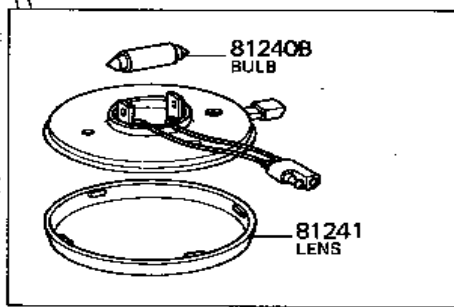
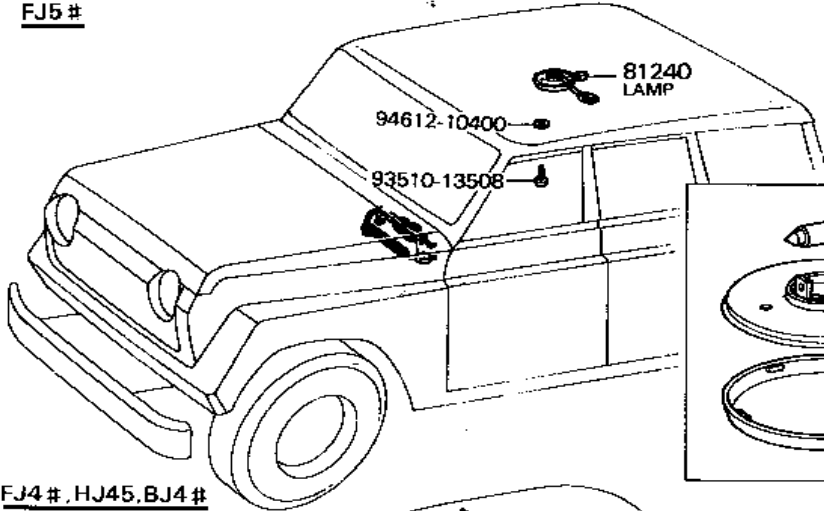

FJ4 #, HJ45, BJ4 #

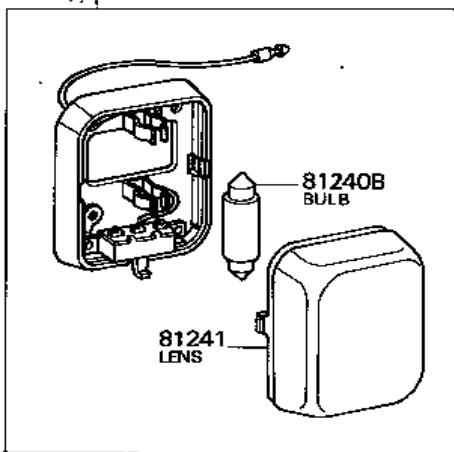
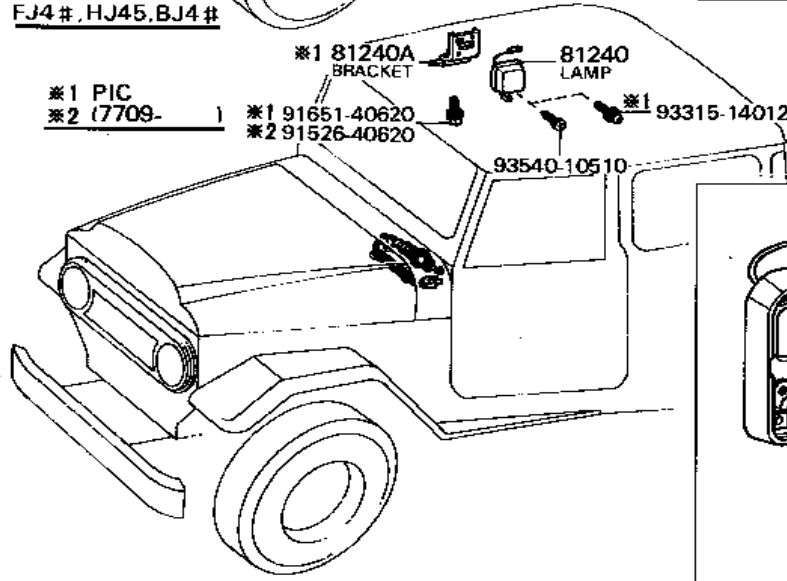

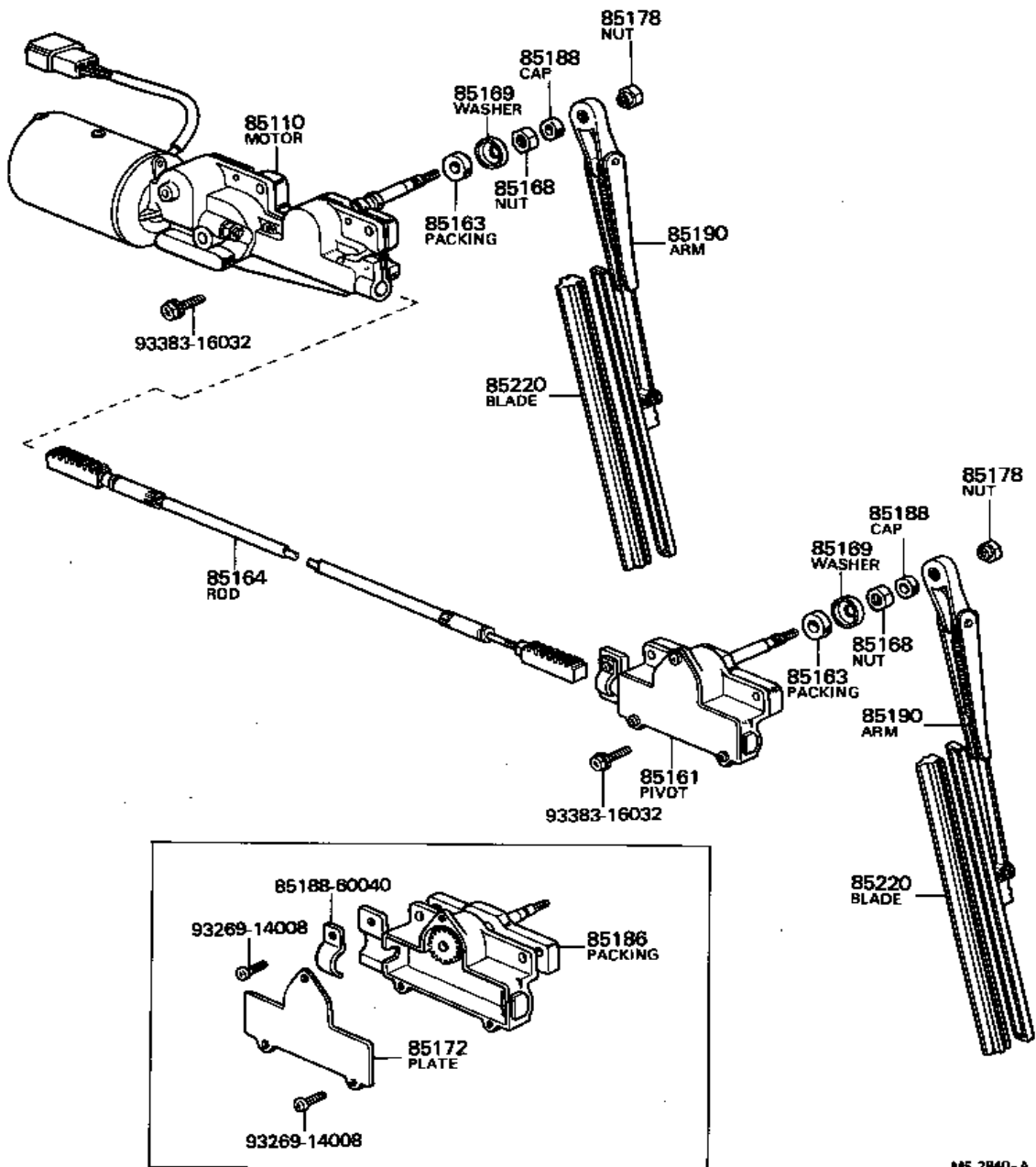

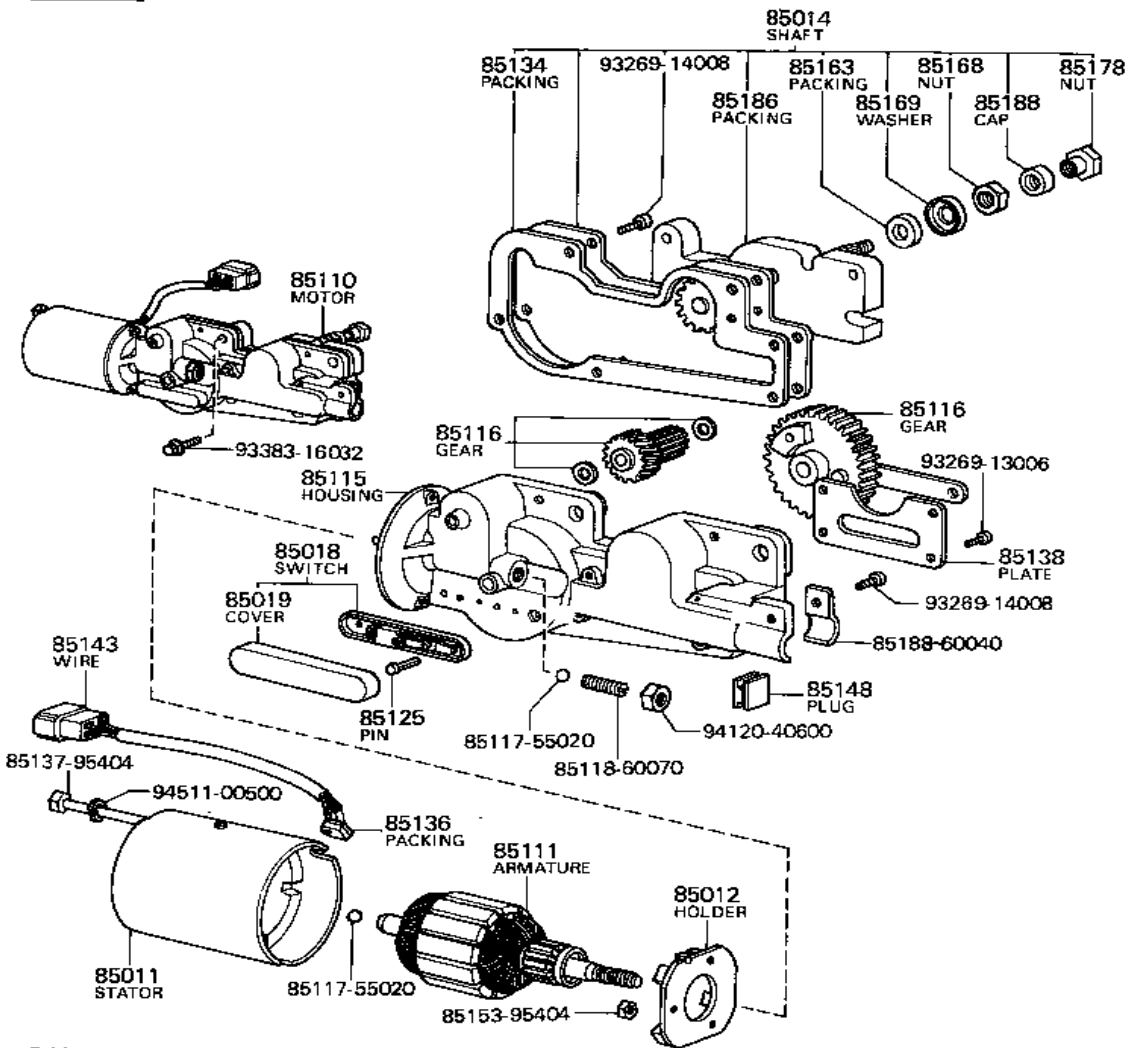

BJ4 #

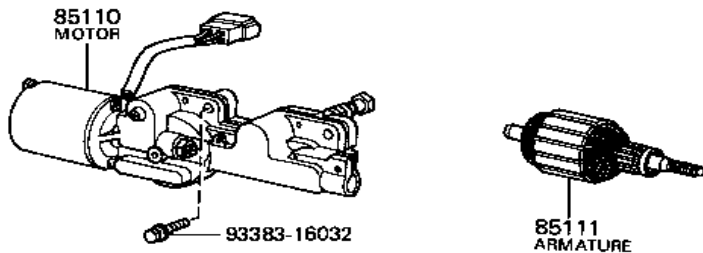

Hinged Windshield Wiper

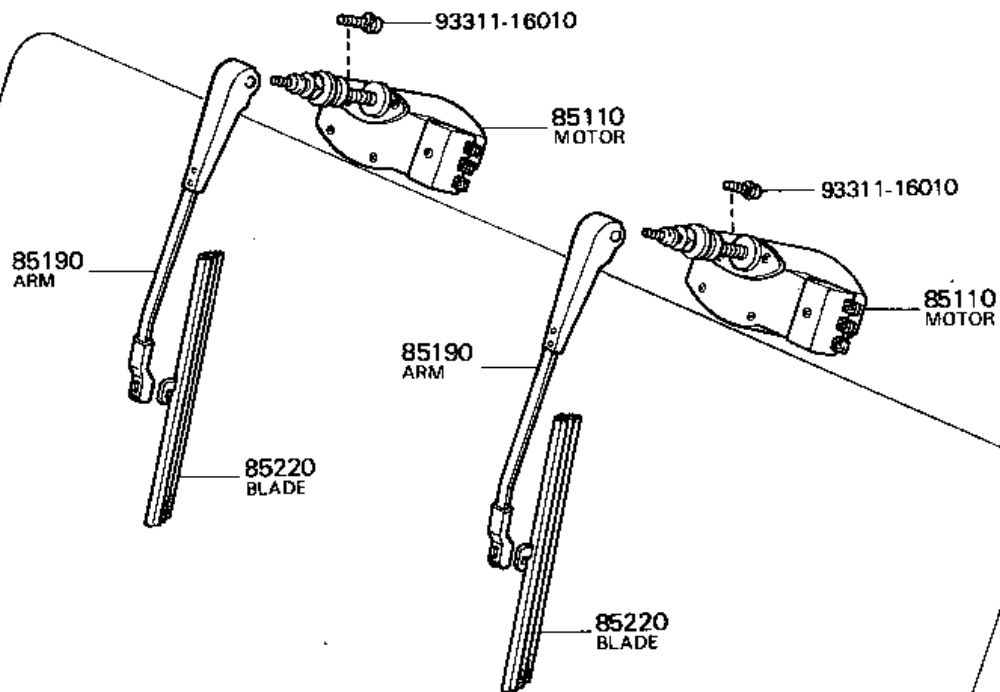

ME 5962

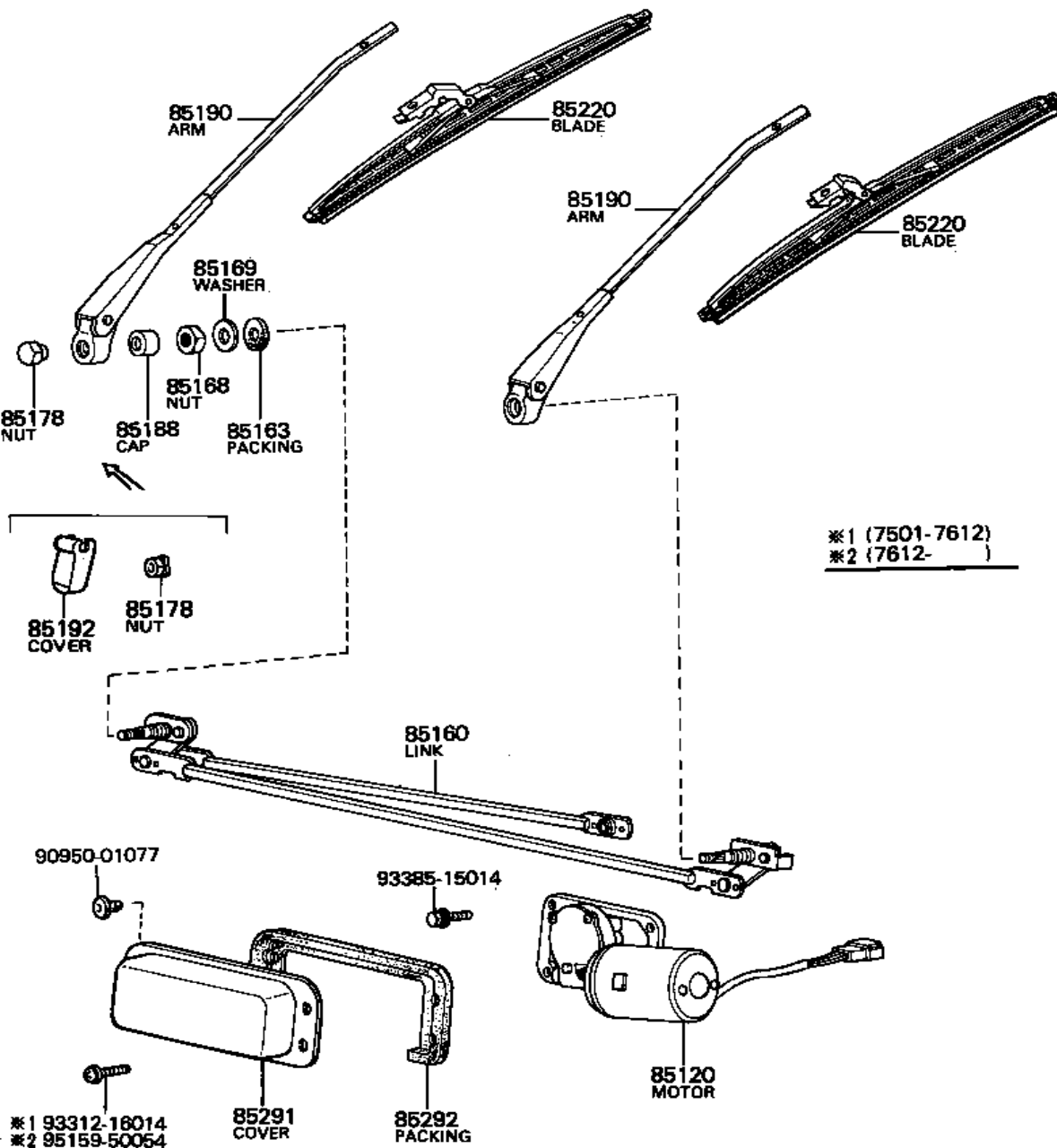

FJ4#, HJ45, BJ4#(7309-) , FJ5#(7401-)

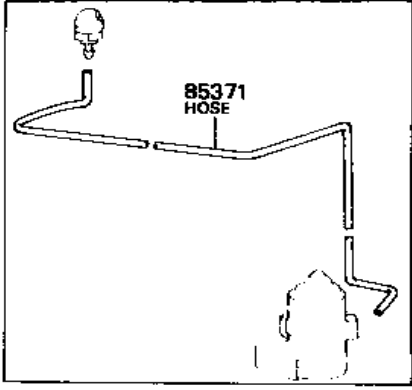

※1 12V System
※2 24V System

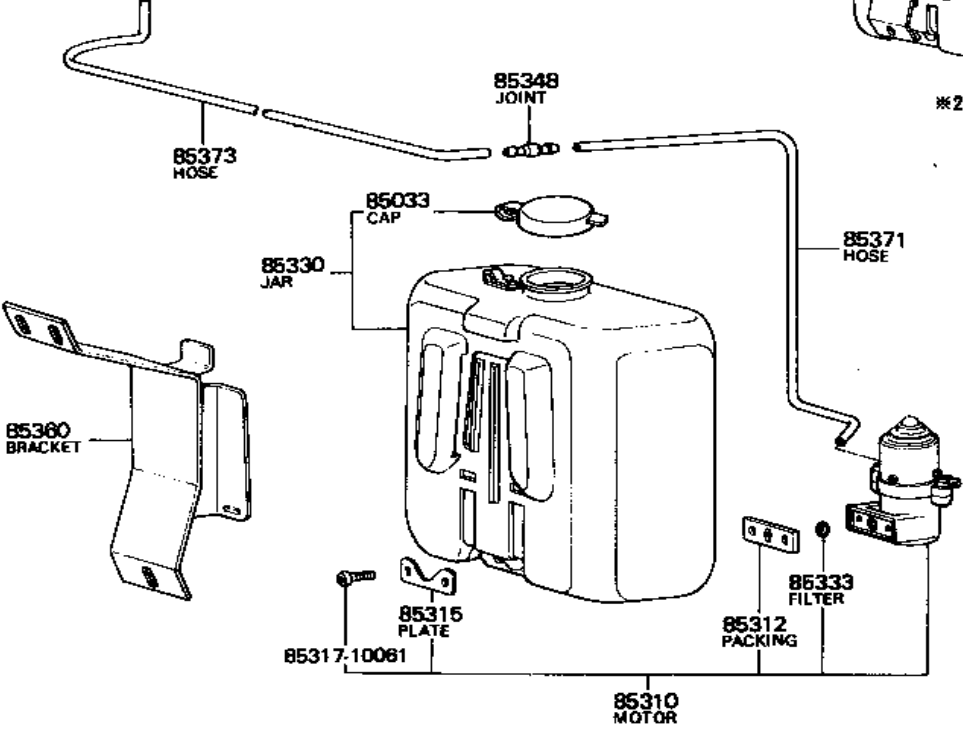
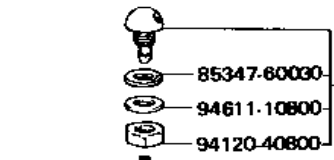
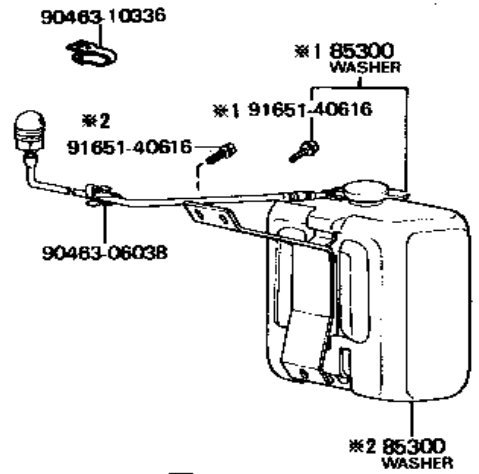

FOR 2.5 LITER

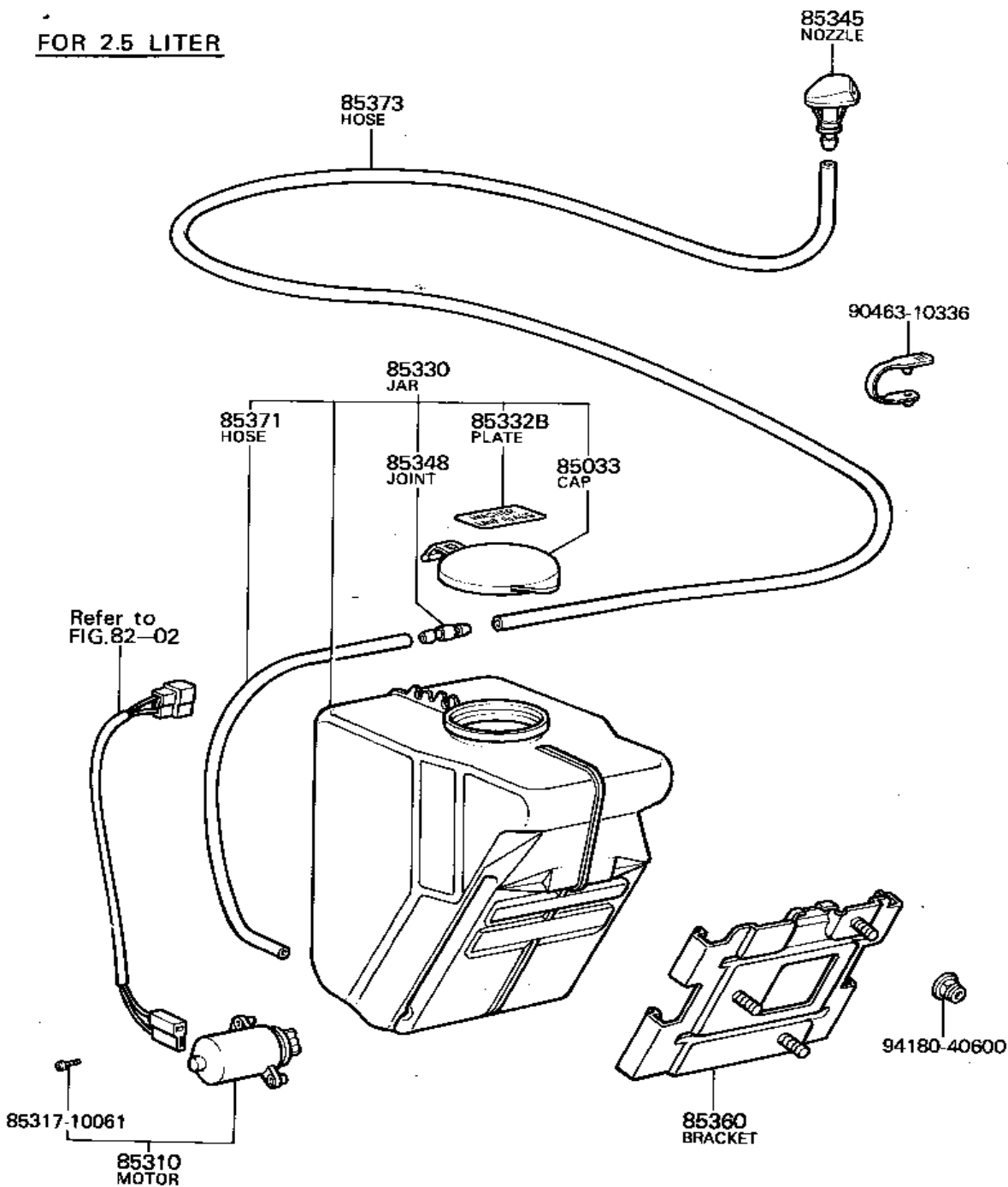

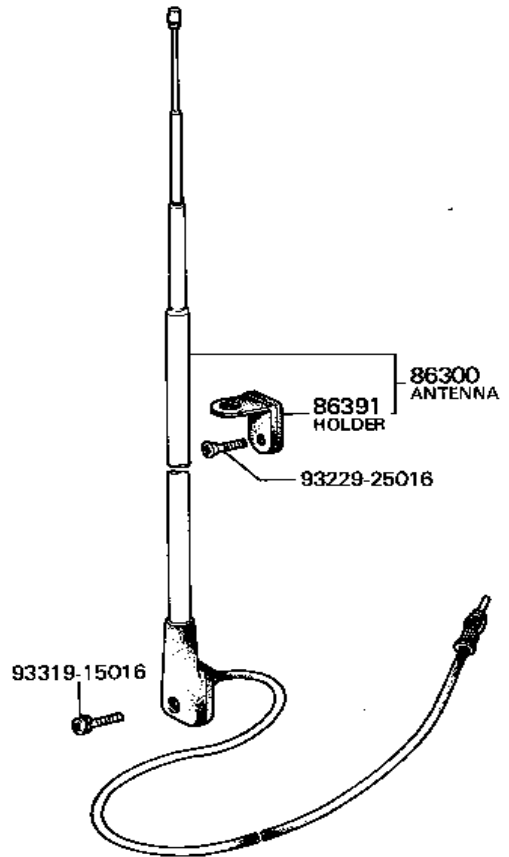
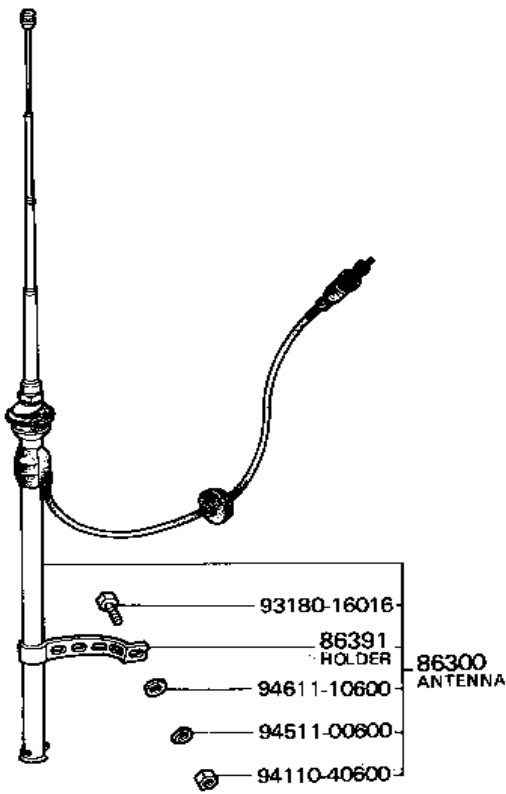

FJ4#, HJ45, BJ4# (7901-)

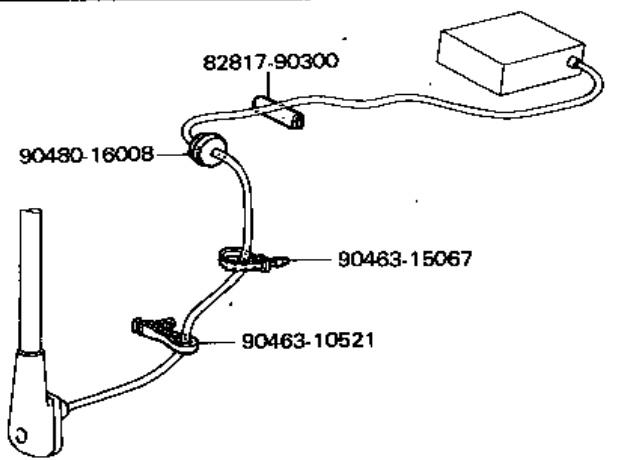

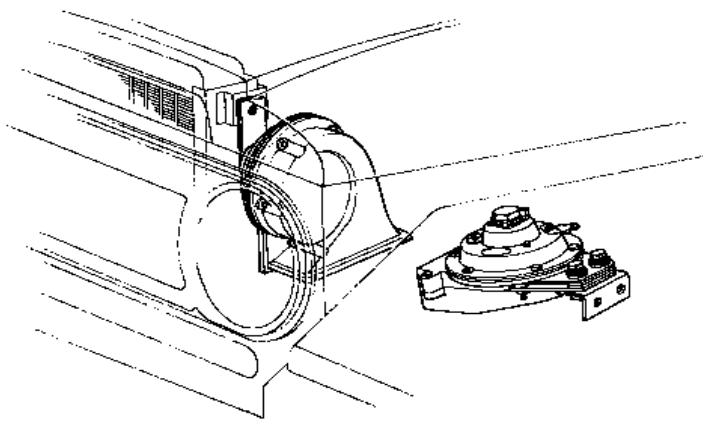

91656-40820

86500
HORN

86520
HORN,LOW

86510
HORN,HIGH

*1 (-7711)
*2 (7711 -)

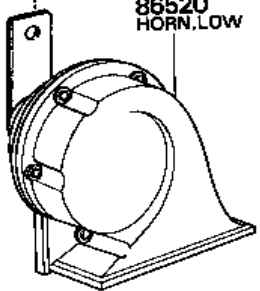

91656-40820

91656-40820

86508
BRACKET

(7709-)

*2 91656-40820
*1 91651-40814

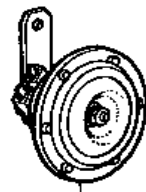

86520
HORN,LOW

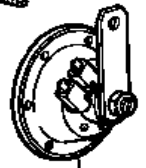

86510
HORN,HIGH

ME 2842-F

FJ4#, HJ45, BJ4# (-7709)

- ※1 W/Breakaway Type (脱落式)
- ※2 L/Breakaway Type (非脱落式)

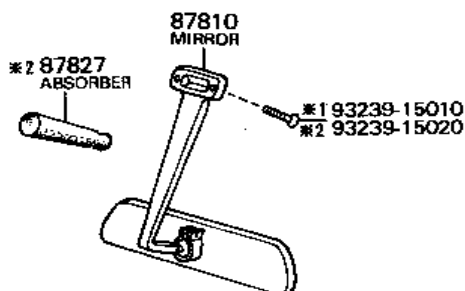

FJ55 (-7709)

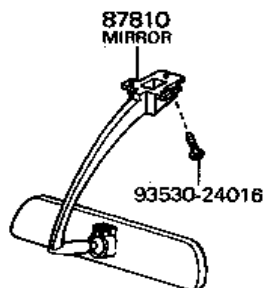

FJ4#, HJ45, BJ4#

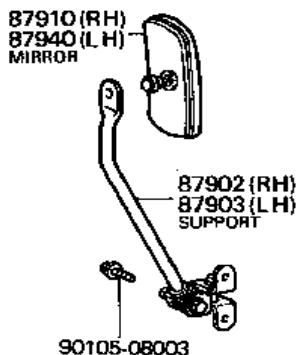

FJ55

(7312-7709)

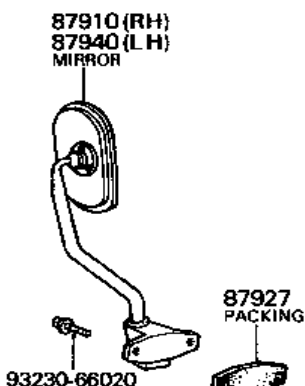

(6903-7312)

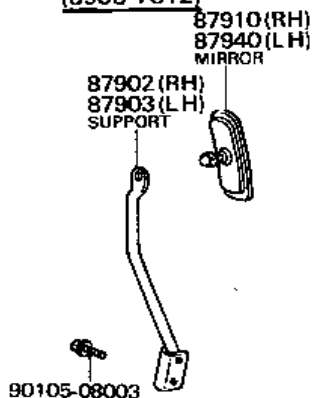

FJ4#, HJ45, BJ4# (7608-)
FJ55 (7709-)

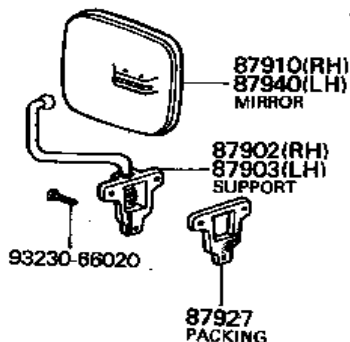

FJ55..Australia

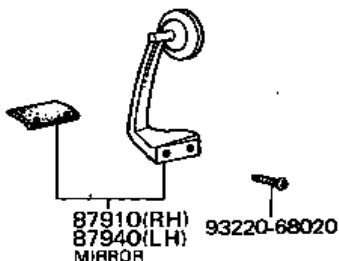

FJ4#, HJ45, BJ4#..Australia

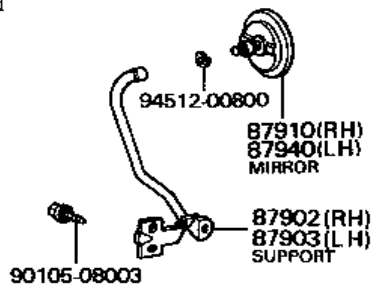

FJ4#,HJ45,BJ4# (6903-)

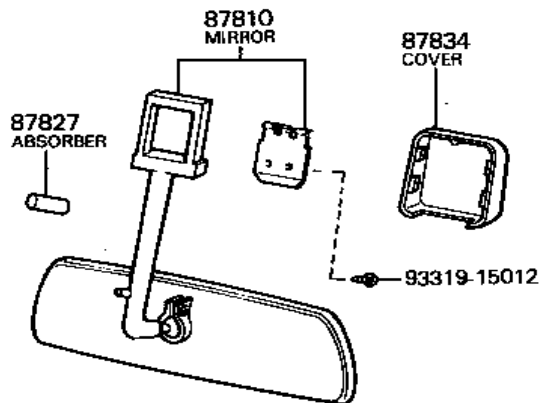

FJ55

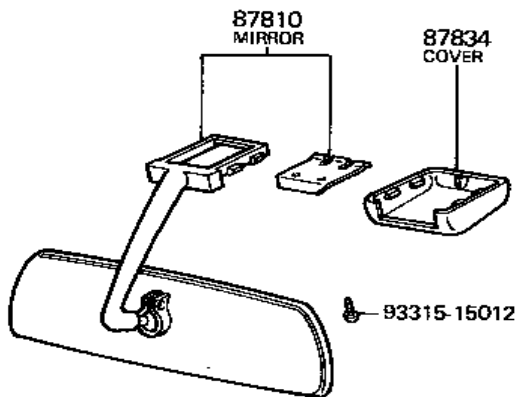

FJ4#,HJ45,BJ4# .EUR (6903-)

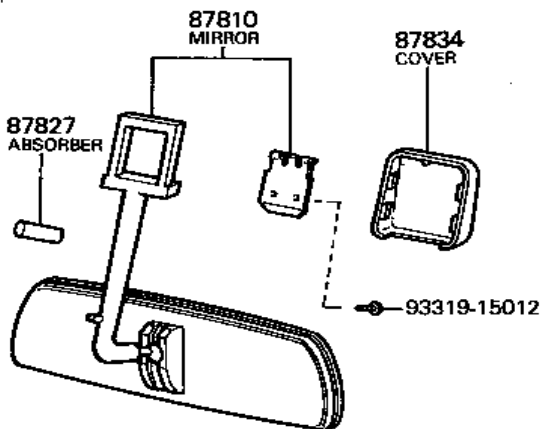

FJ55 .EUR,ARL

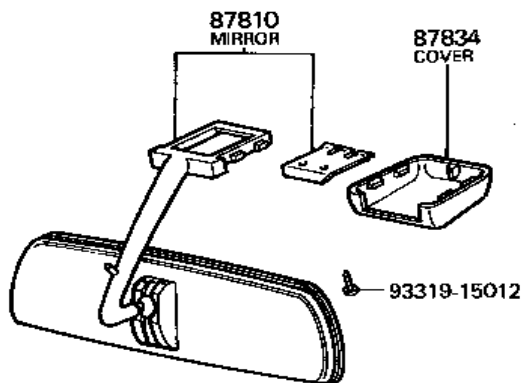

FJ4#,HJ45,BJ4# .EUR

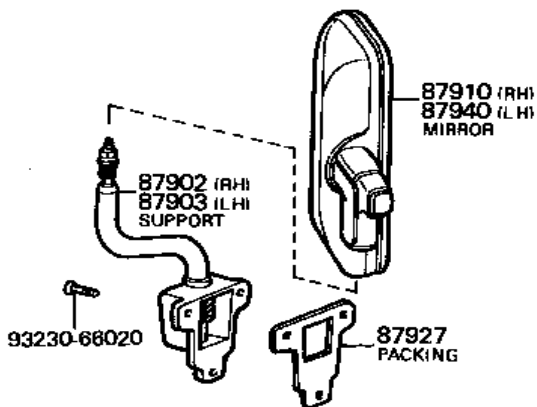

FJ55 .EUR

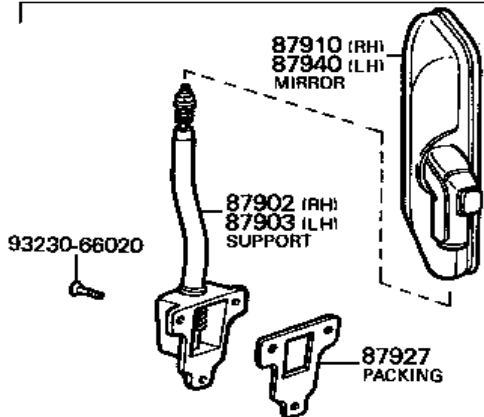

HJ45

(-7901)

W/ELECTRICAL WINCH

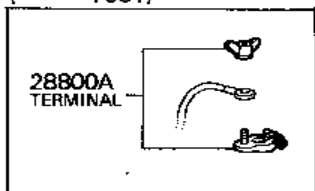
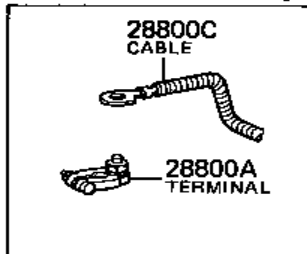

For 24V

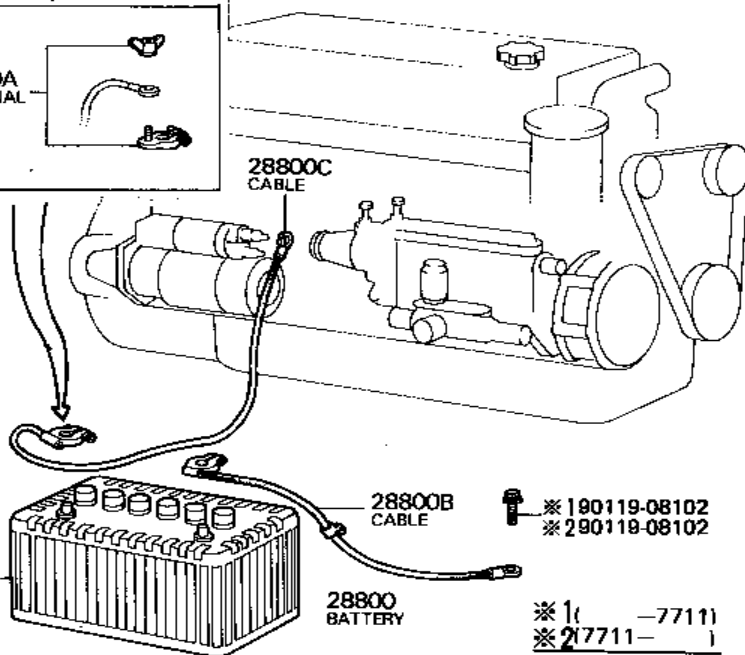
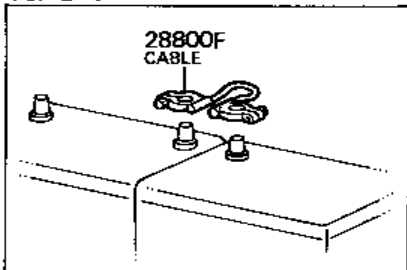

BJ4#

W/ELECTRICAL WINCH

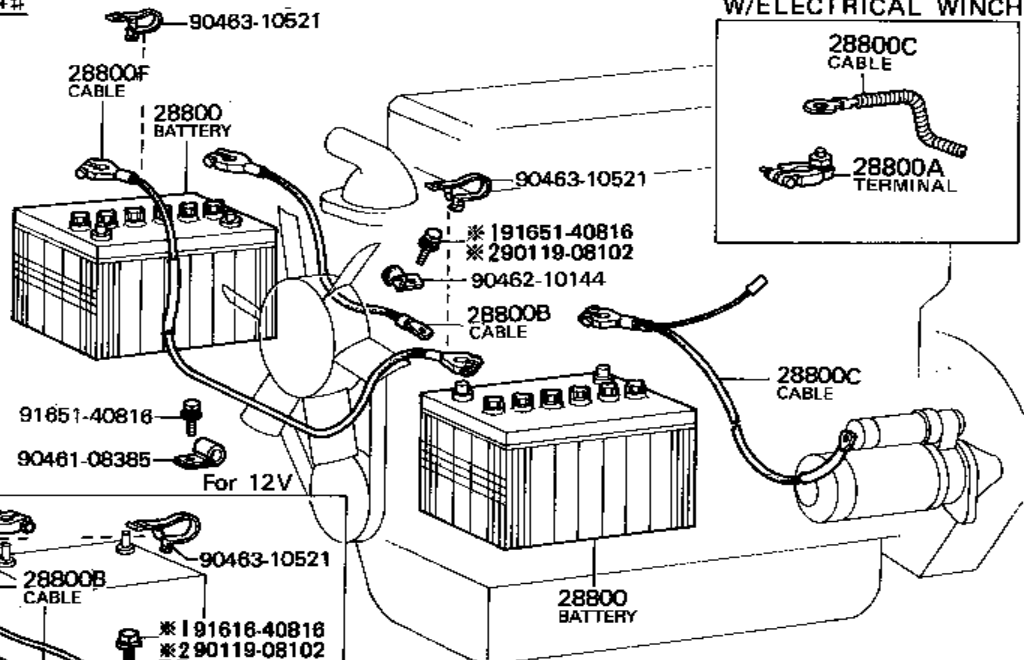
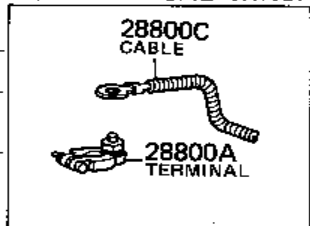

For 12V

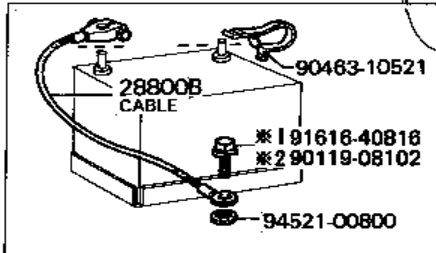

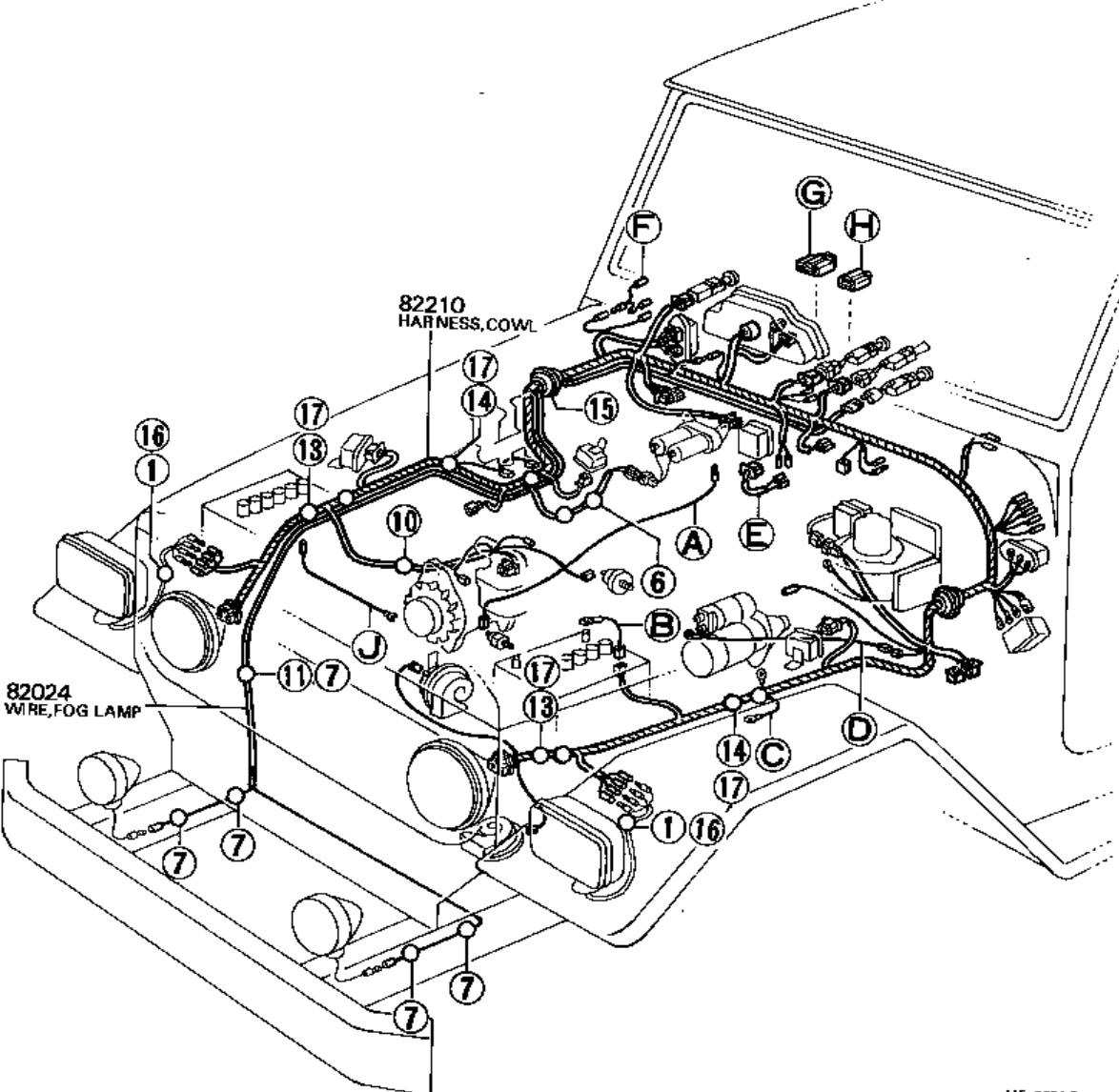



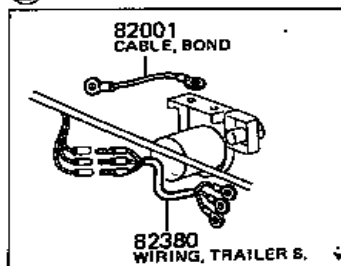
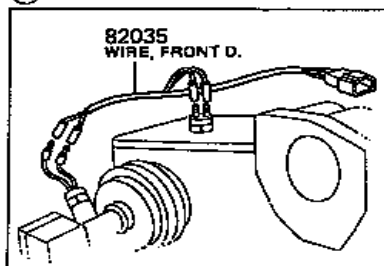
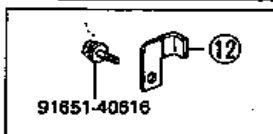
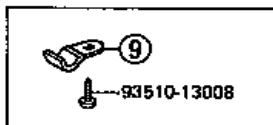
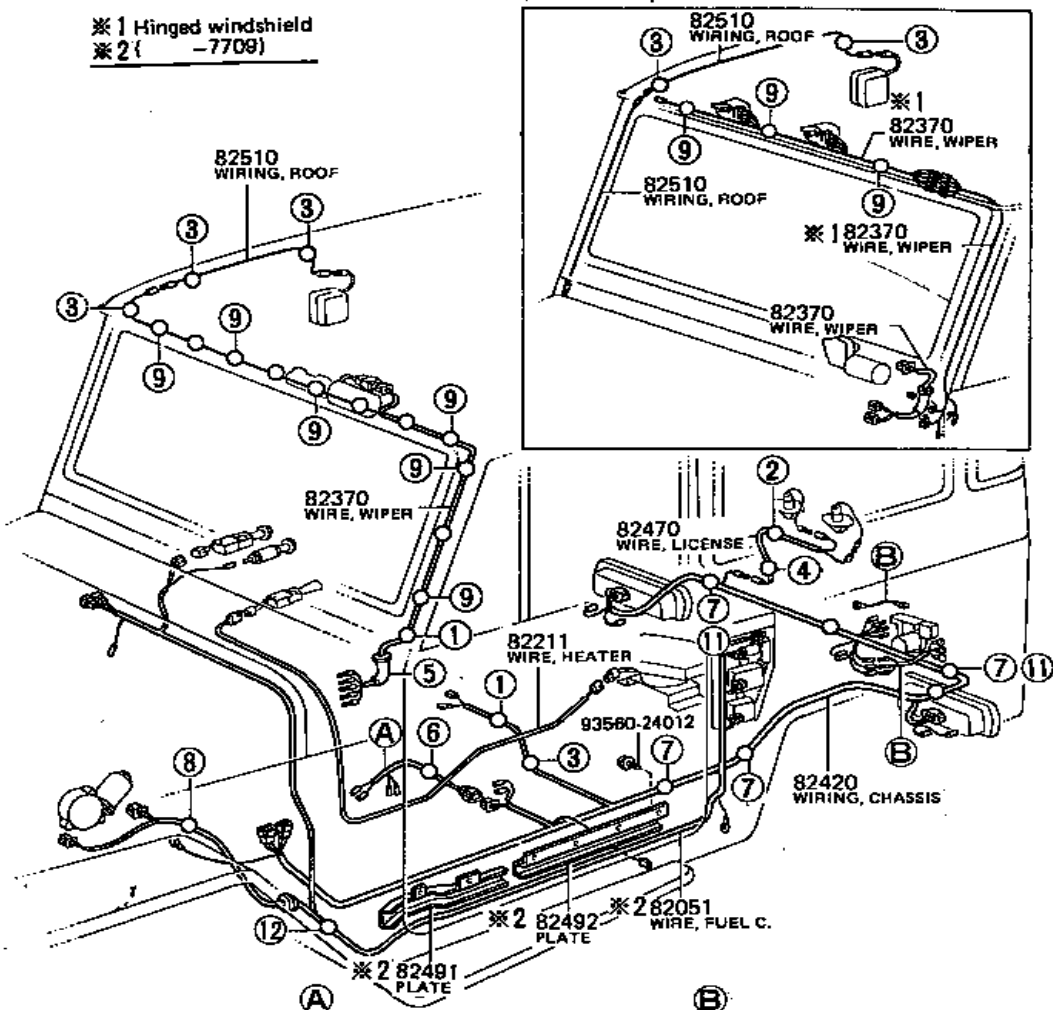

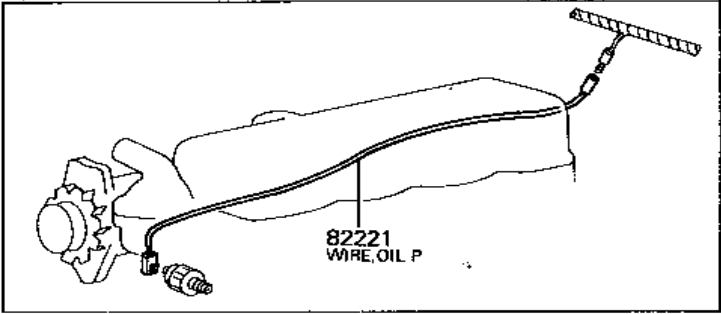
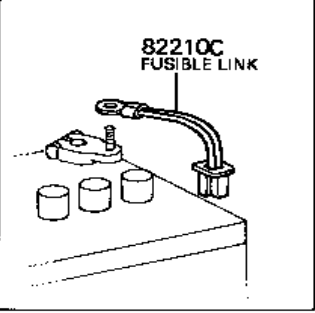
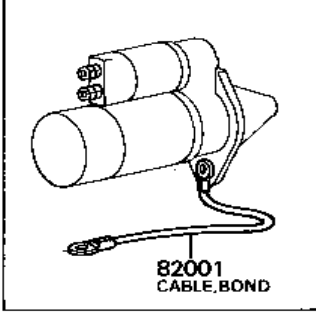
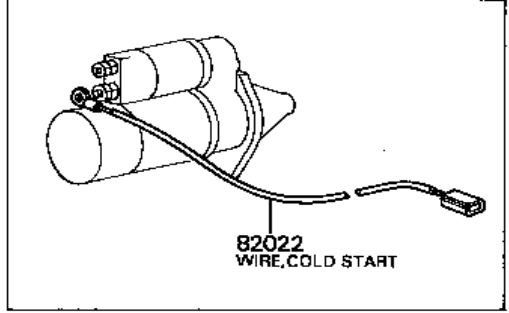
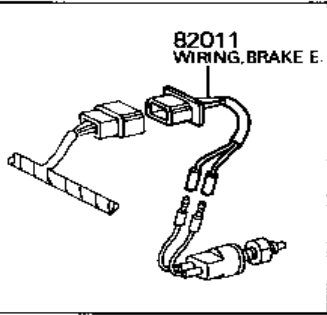
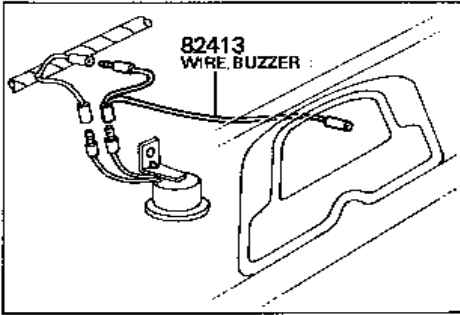
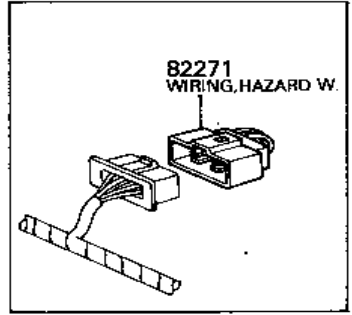
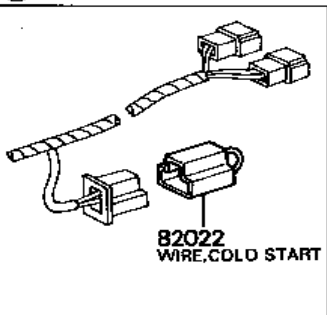
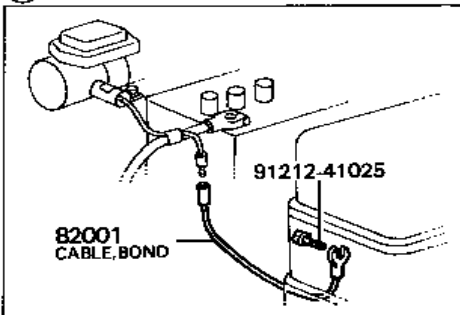



















※ 1 Hinged windshield
 ※ 2 (-7709)





A**B****C****D****E****F****G****H****J**

NO.	①	②	③	④	⑤	⑥	⑦	⑧
TYPE								
PART NO.	90480-15007	90480-18214	90480-10300	90480-22082	82818-60010	90461-08852	90463-08030	90463-06161
MODELS	all	all	all	all	all	all	all	all
PROD. DATE	7402-	7402-	7402-	7402-	7402-	7402-	7402-	7402
QTY.	4	1	4	1	1	1	11	3



NO.	⑨	⑩	⑪	⑫	⑬	⑭	⑮	⑯
TYPE								
PART NO.	90462-08213	90463-04079	90463-08375	90461-12009	90463-10335	90463-10336	90480-30003	90480-15172
MODELS	all	all	all	all	all	all	all	all
PROD. DATE	7402-7501	7402-	7402-	7402-	7501-7612	7501-7612	7801-	7701-
QTY.	11	1	2	1	7	9	1	2

NO.	⑰	⑱	⑲	⑳	㉑	㉒	㉓	㉔
TYPE								
PART NO.	90463-10521	90480-15194	90480-18011	90480-21511	90480-19374	90461-08911	90480-14338	82819-90305
MODELS	all	vkcc	all	all	all	all	all	TP
PROD. DATE	7612-	7709-	7709-7804	7709-	7709-	7709-	7801-	7804-
QTY.	12	2	1	1	1	2	1	1

NO.	㉕	㉖	㉗	㉘	㉙	㉚	㉛	㉜
TYPE								
PART NO.	90463-10335	90484-00165	90467-10007					
MODELS	TP	all	TP					
PROD. DATE	7804-	7803-	7806-					
QTY.	1	2	3					

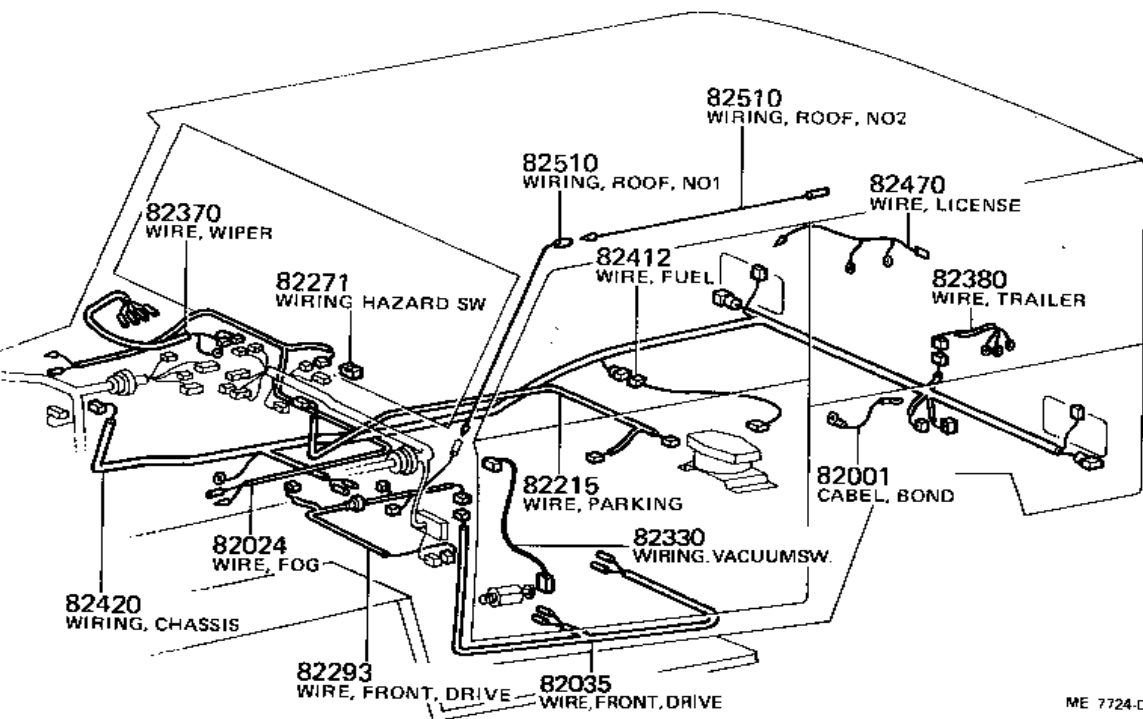
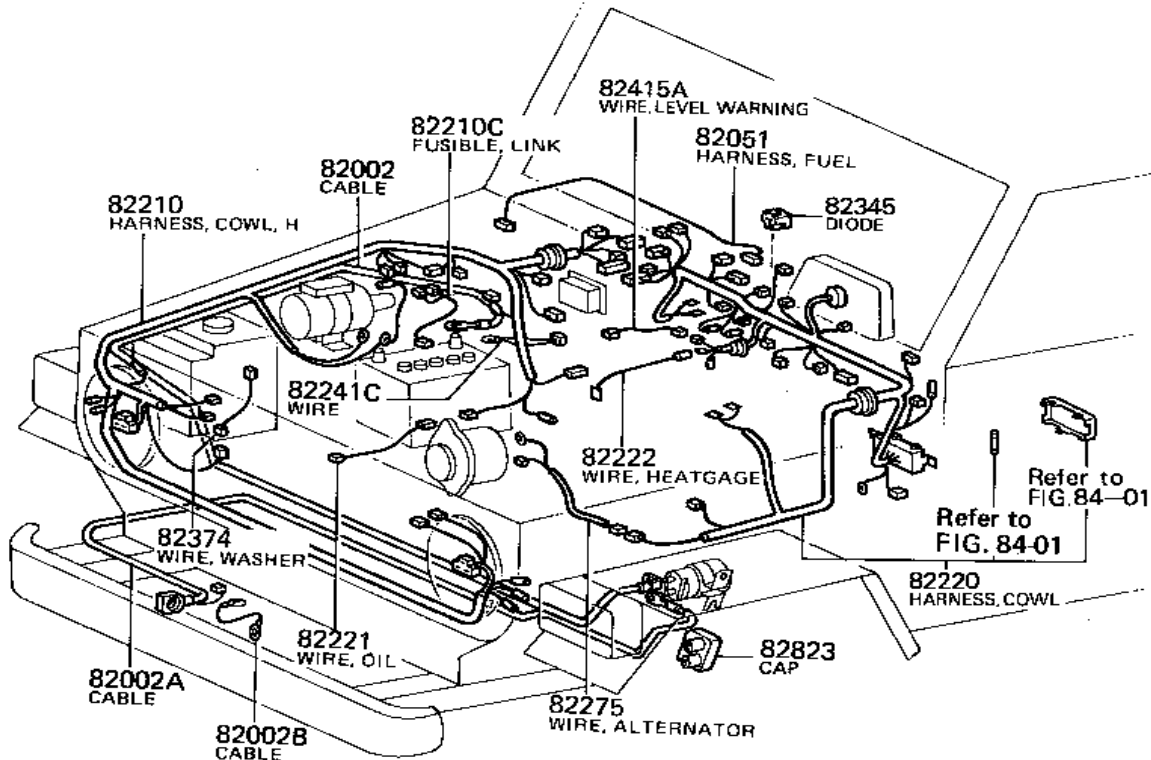
NO.	㉝	㉞	㉟	㊱	㊲	㊳	㊴	㊵
TYPE								
PART NO.								
MODELS								
PROD. DATE								
QTY.								

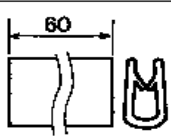

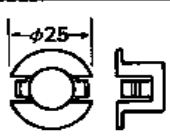
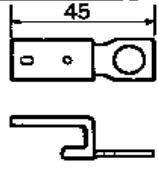
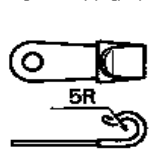
NO.	①	②	③	④	⑤
TYPE					
PART NO.	82817-90300	82818-90300	82819-90305	90461-06083	90461-08090

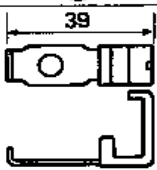
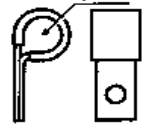
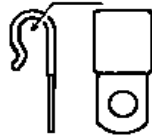
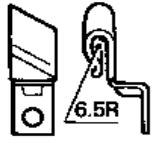
NO.	⑥	⑦	⑧	⑨	⑩
TYPE					
PART NO.	90461-08192	90461-08202	90461-08385	90461-08430	90461-08911

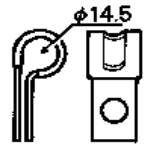
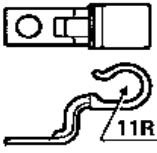
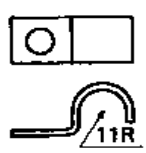
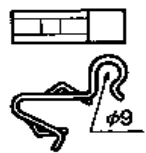
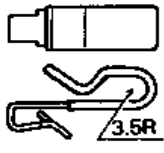
NO.	⑪	⑫	⑬	⑭	⑮
TYPE					
PART NO.	90461-10274	90461-10398	90462-10005	90463-04079	90463-04340

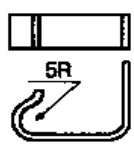
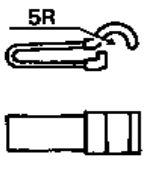
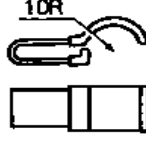
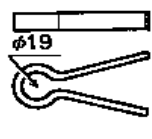
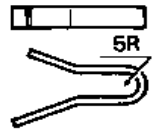
NO.	⑯	⑰	⑱	⑲	⑳
TYPE					
PART NO.	90463-06161	90483-08027	90463-08030	90463-08207	90463-08375

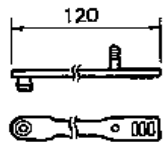
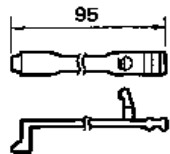
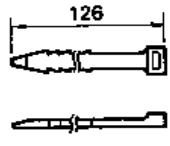
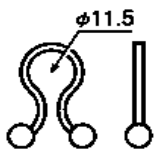
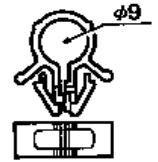
NO.	㉑	㉒	㉓	㉔	㉕
TYPE					
PART NO.	90463-10010	90463-10521	90463-15067	90464-00190	90467-10007

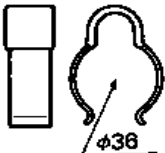
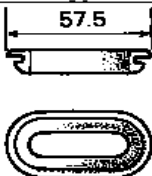
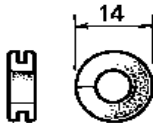
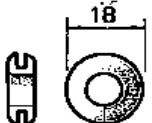
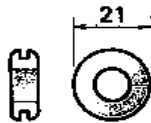
NO.	26	27	28	29	30
TYPE					
PART NO.	90467-36135	90480-01316	90480-10300	90480-13334	90480-15007

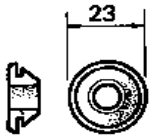
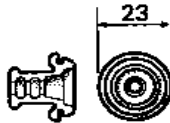
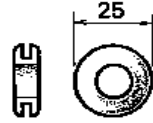
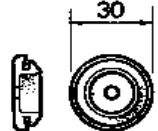
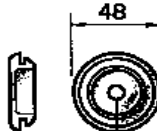
NO.	31	32	33	34	35
TYPE					
PART NO.	90480-15172	90480-15194	90480-18011	90480-21511	90480-36508

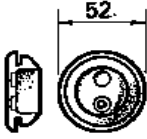
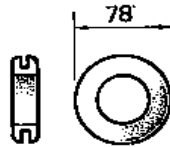
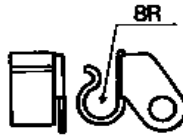
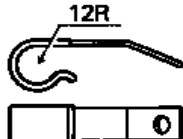
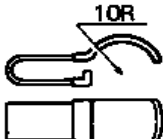
NO.	36	37	38	39	40
TYPE					
PART NO.	90480-40303	90480-58059	90461-08026	90461-10478	90463-08026

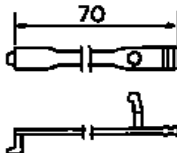
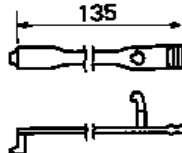
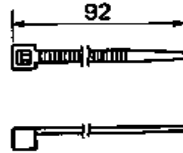
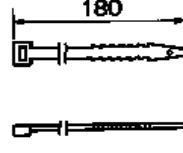
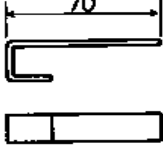
NO.	41	42	43	44	45
TYPE					
PART NO.	90463-10012	90463-10060	90463-12570	90463-15454	90463-04573

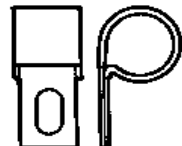
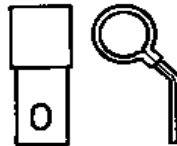
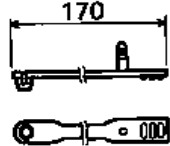
NO.	46	47	48	49	
TYPE					
PART NO.	90461-08213	90461-12543	90461-12690	90463-10024	

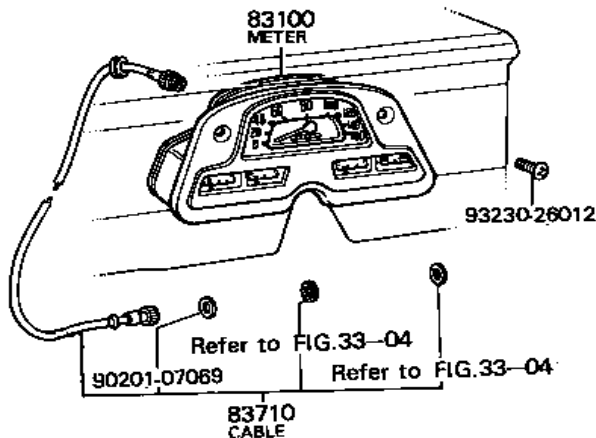

Speedometer Cable Clamp

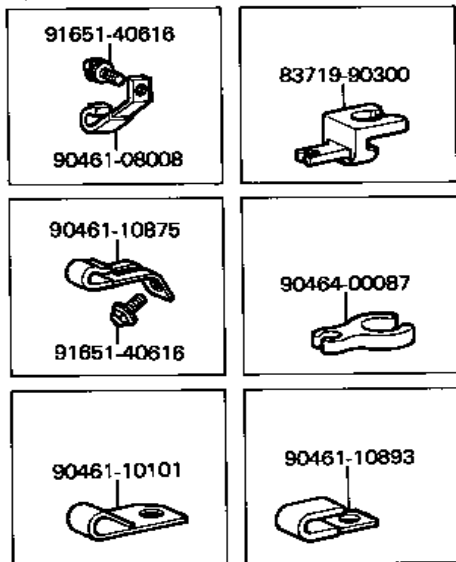

Ⓔ 輸出用
For Export

※(7910-)

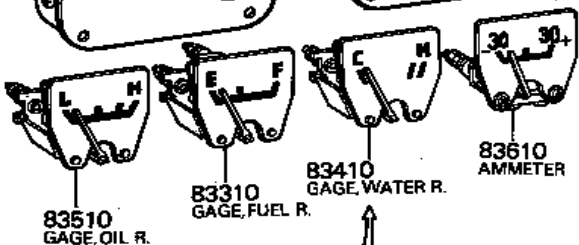
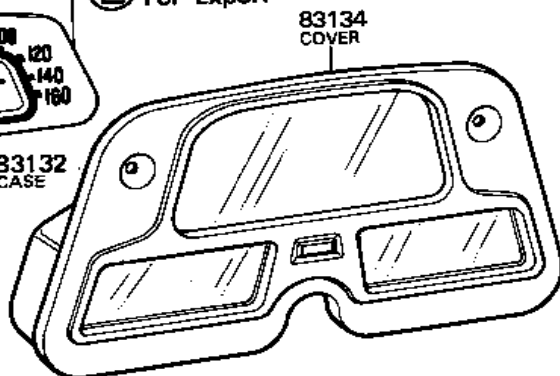
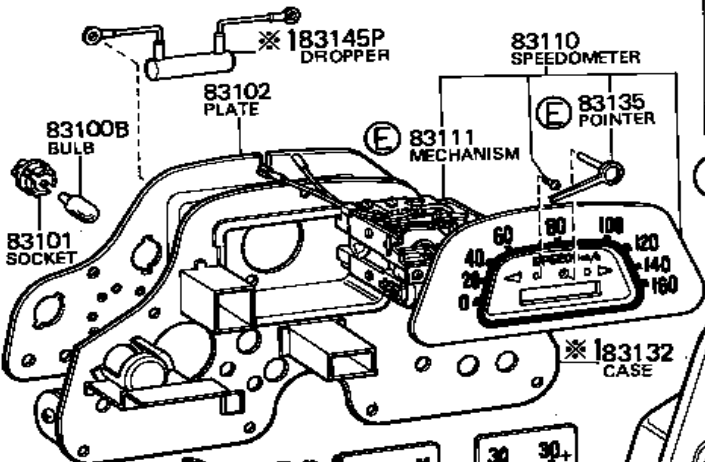

(7910-)

(7309-7910)

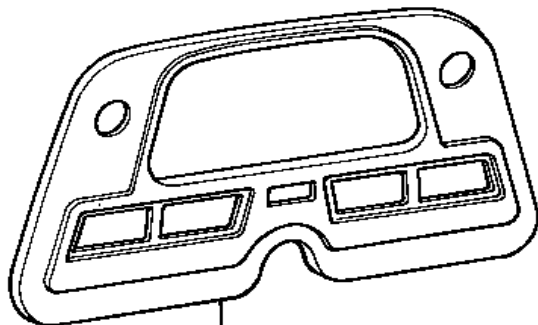

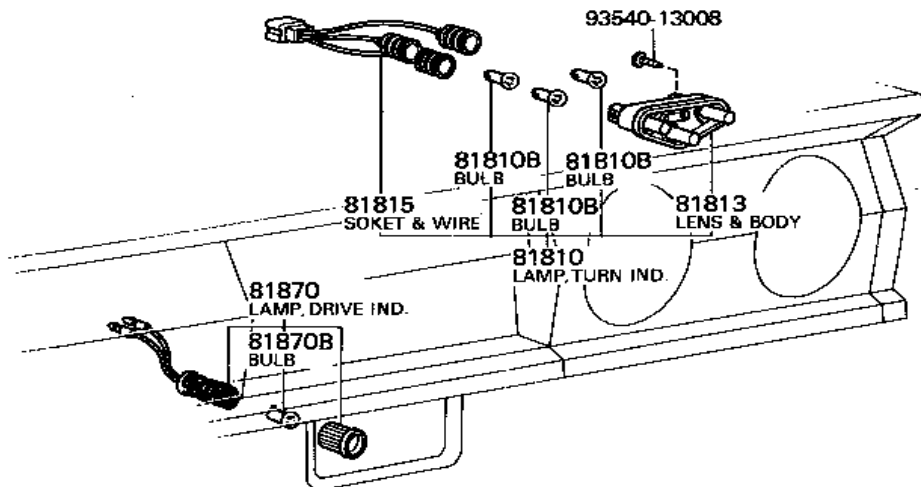
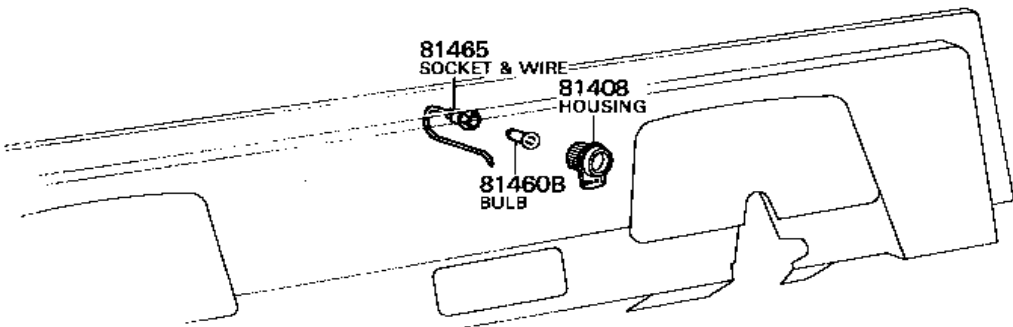
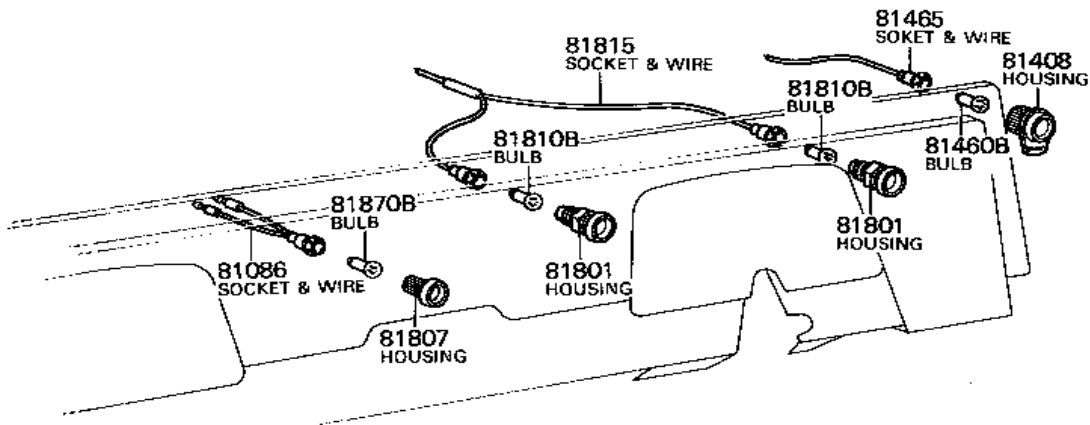

FJ4# .HJ45,BJ4#

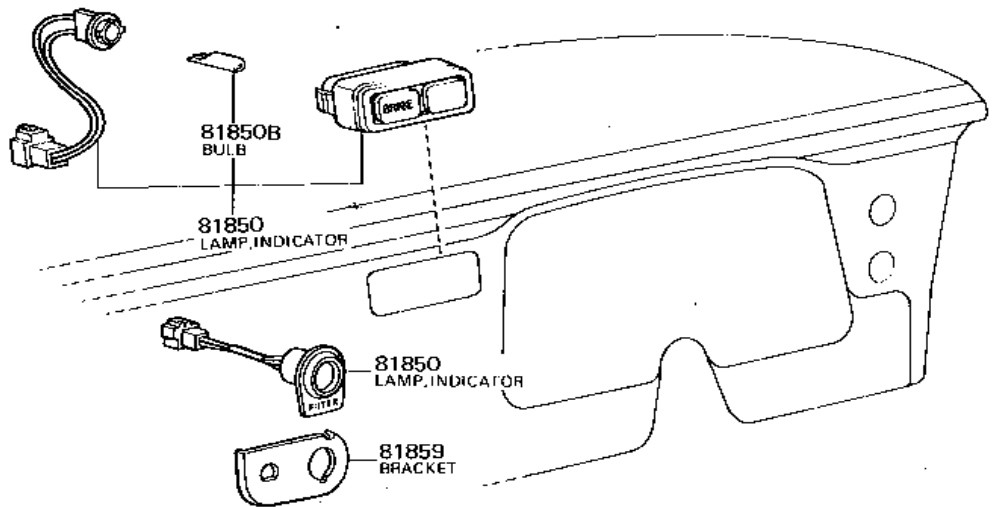

FJ5#

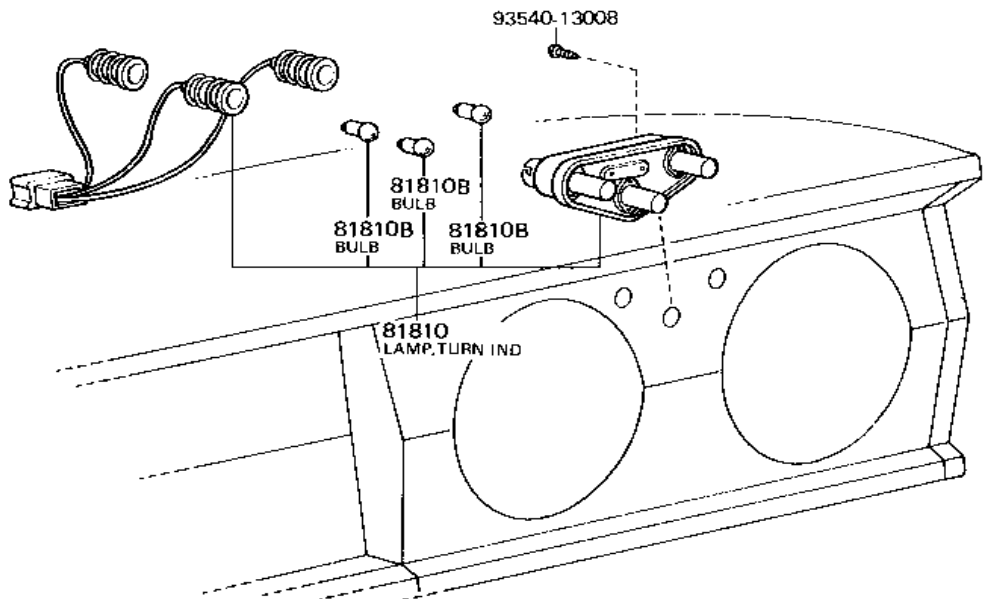

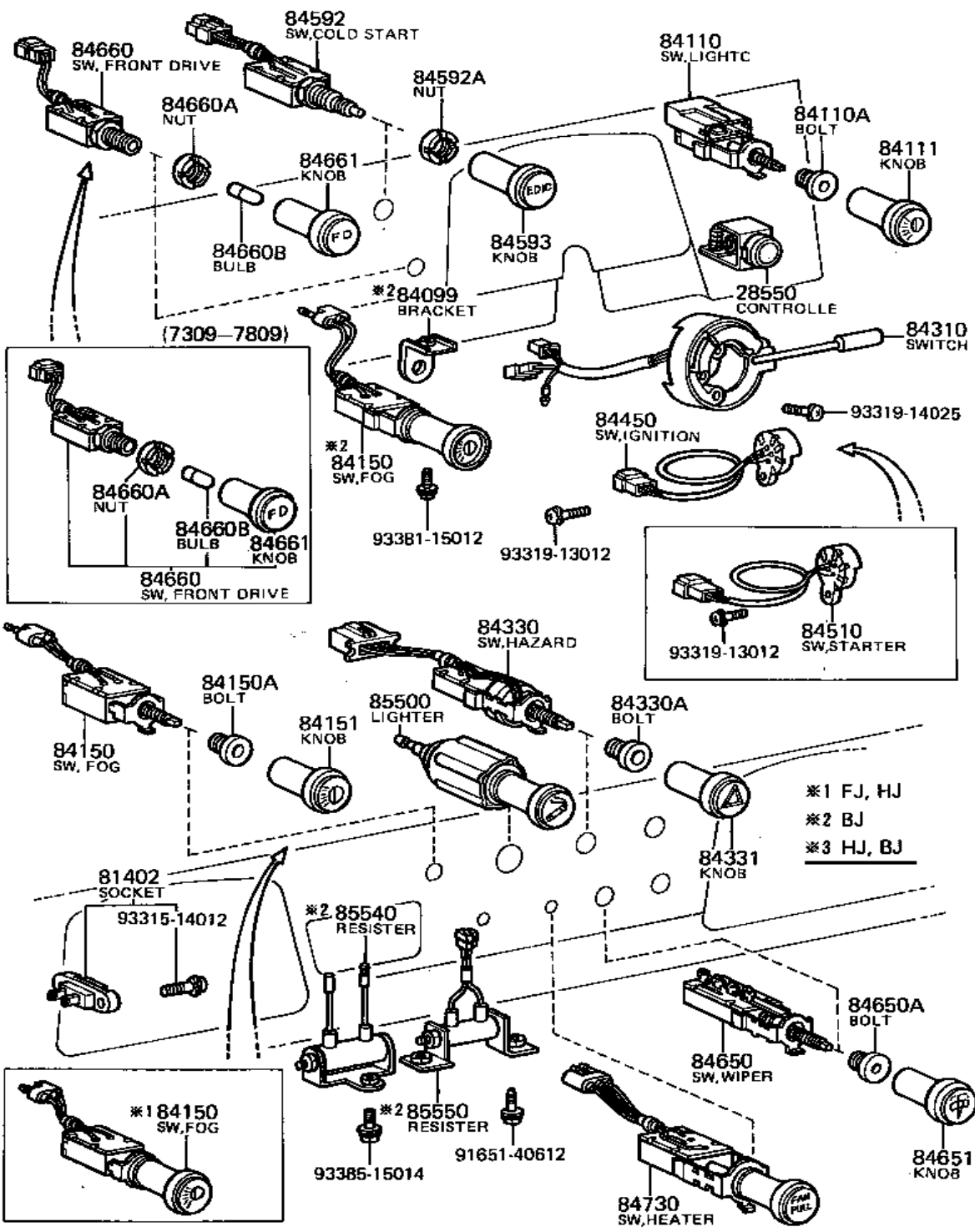

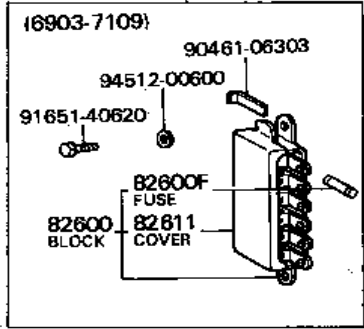
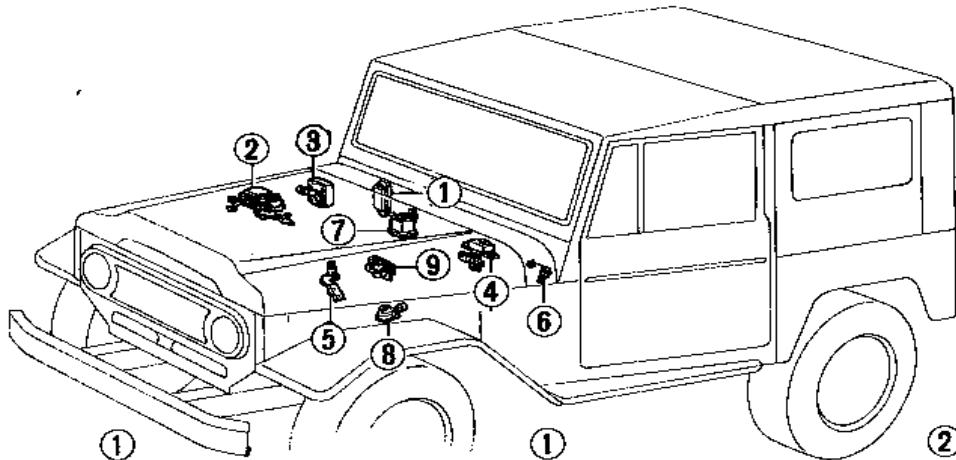

3

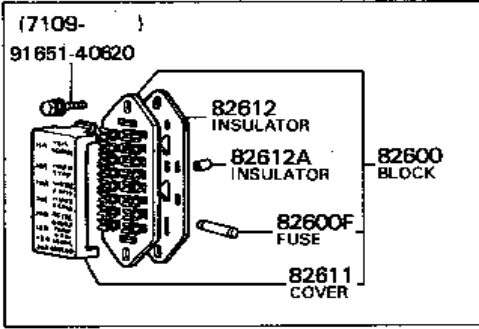

4

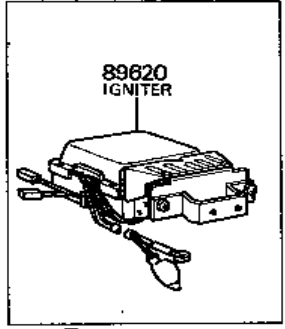

5

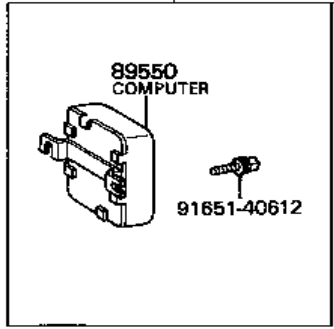

6

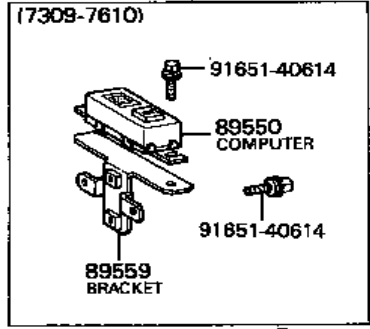

7

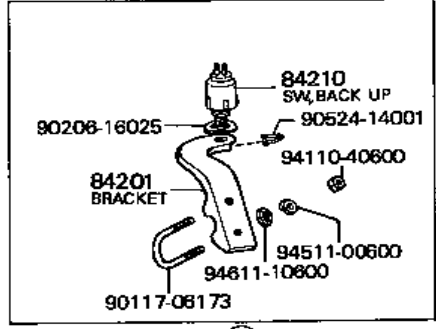

9

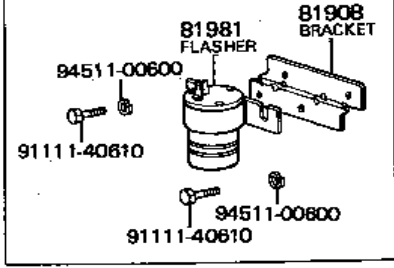
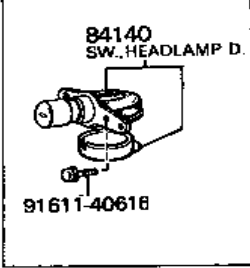
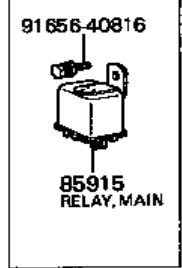
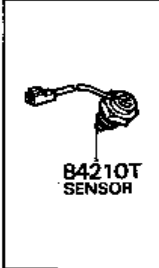

- ※1 FJ4 #, HJ45
- ※2 BJ4 #
- ※3 HJ45, BJ4 #..LHD

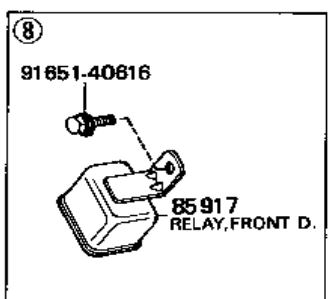
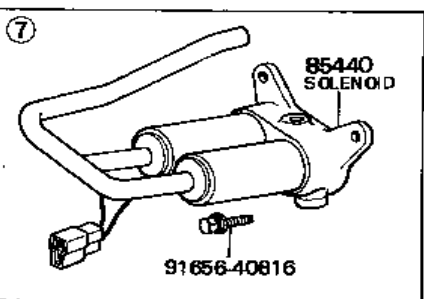
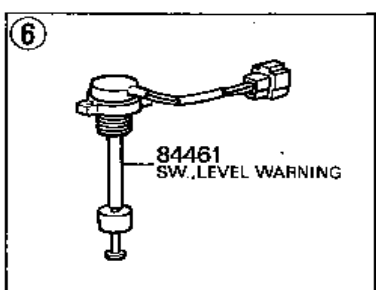
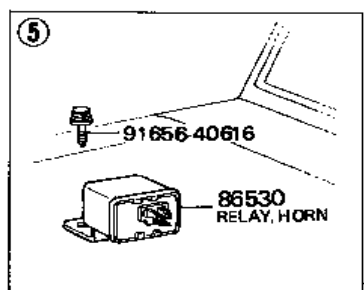
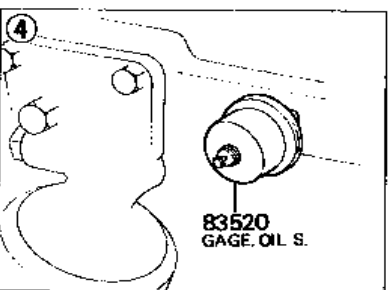
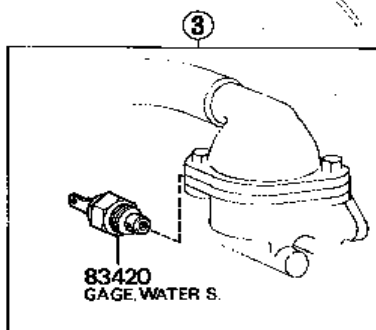
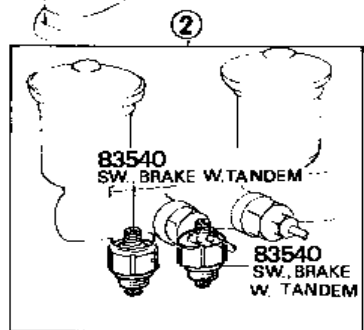
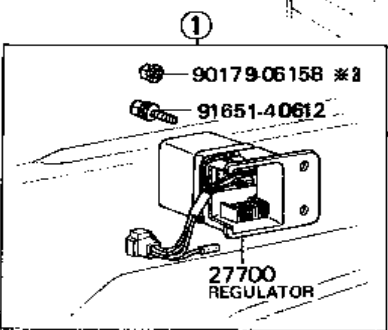
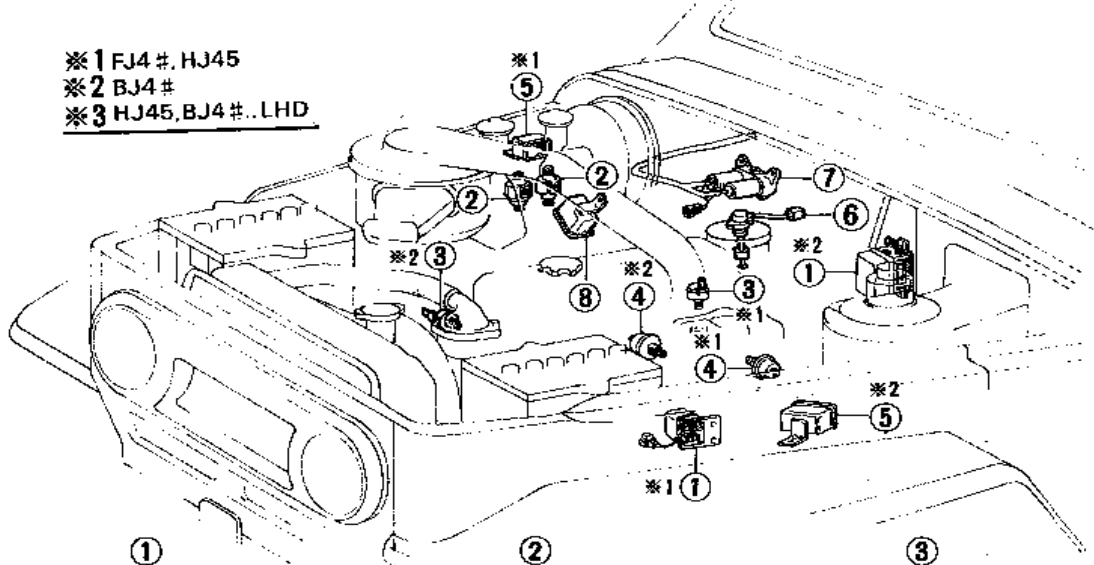

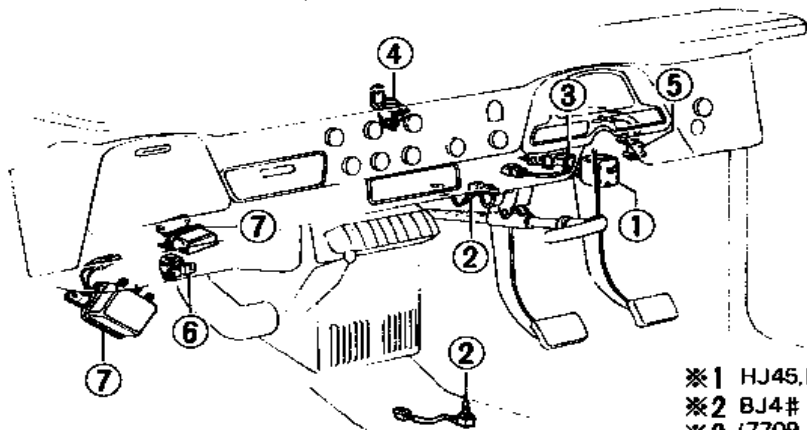

- ※1 HJ45,BJ4#(For 12V System)
- ※2 BJ4# (For 24v System)
- ※3 (7709-

L/Hazard Switch ①

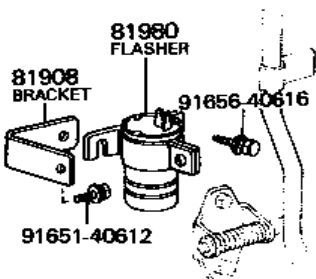

W/Hazard Switch ①

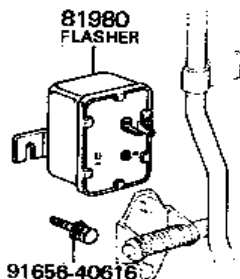

②

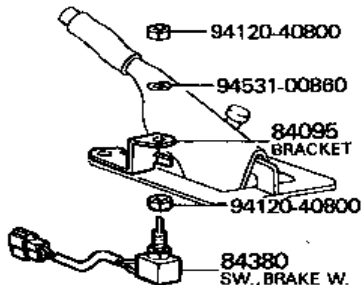

②

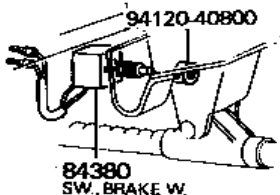

③

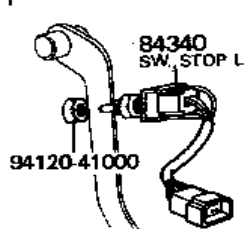

④

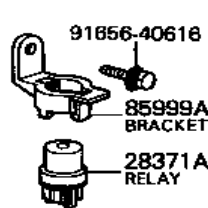

⑤

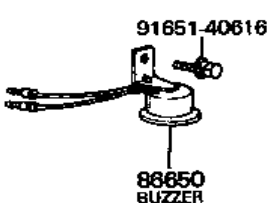

⑥

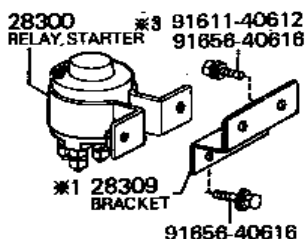

⑦

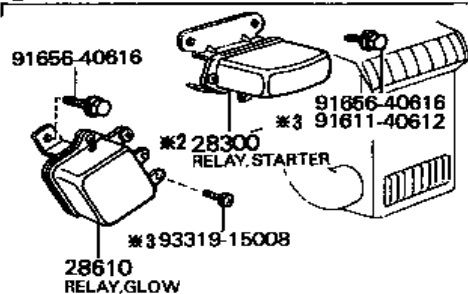

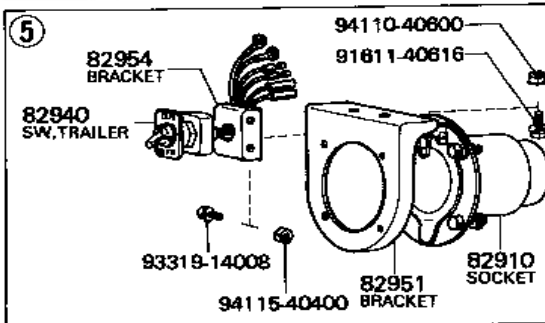
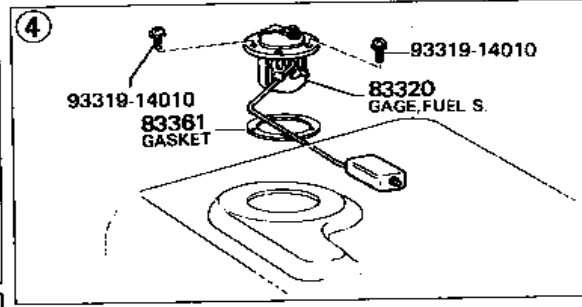
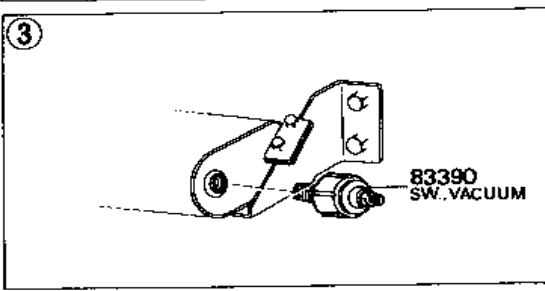
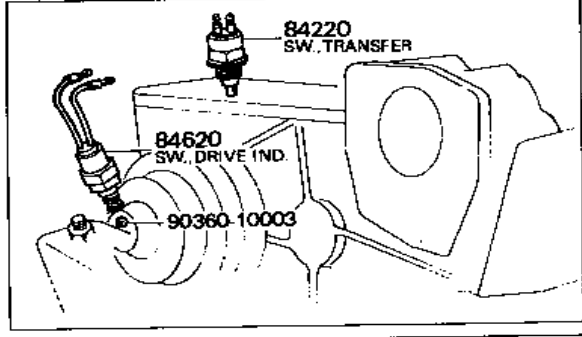
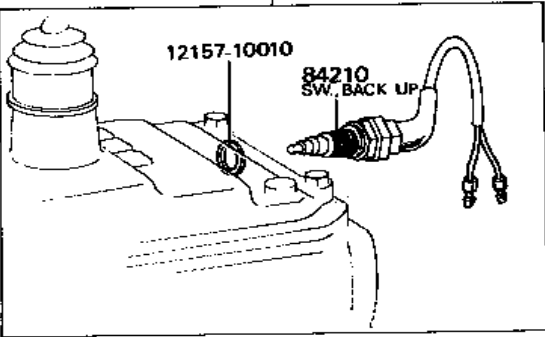
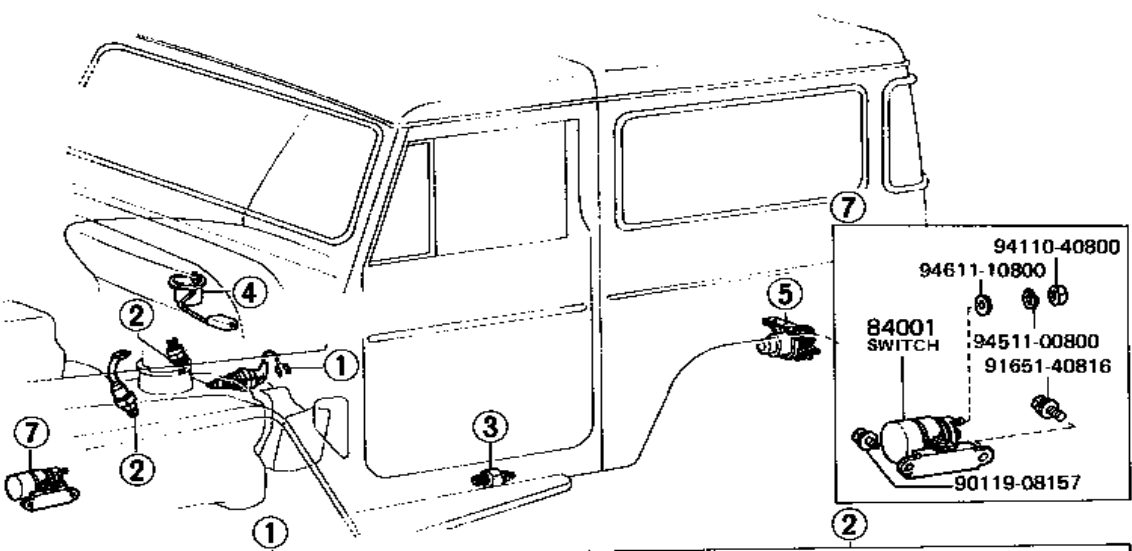

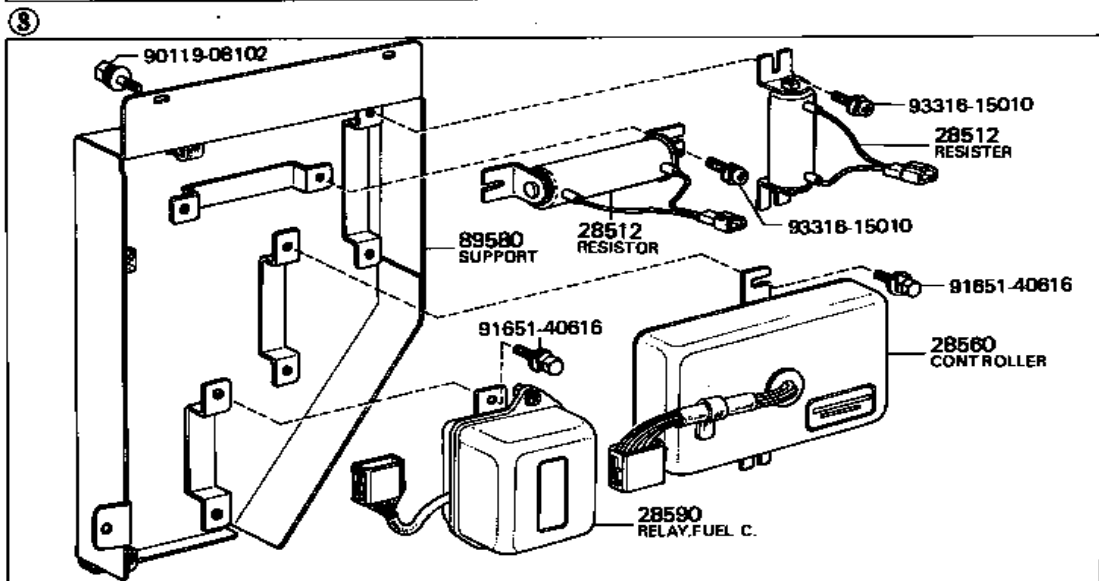
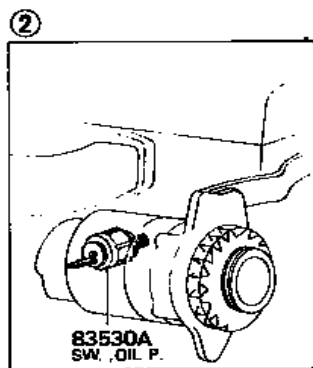
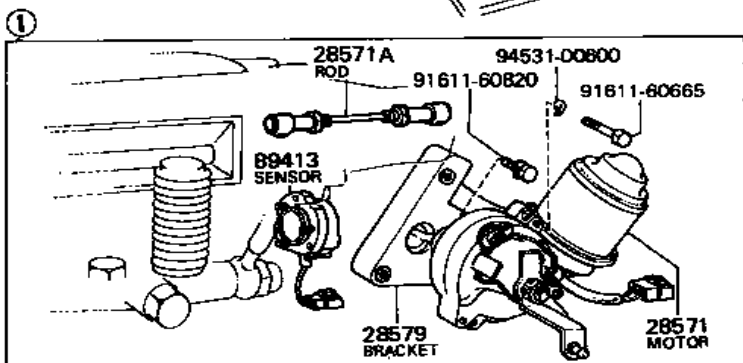
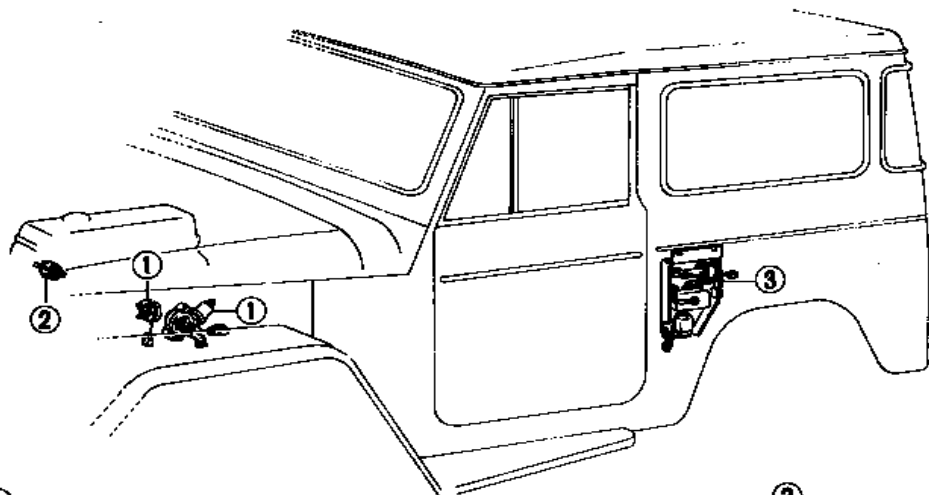

28571A
ROD



91611-60665



94512-00600



28571
MOTOR

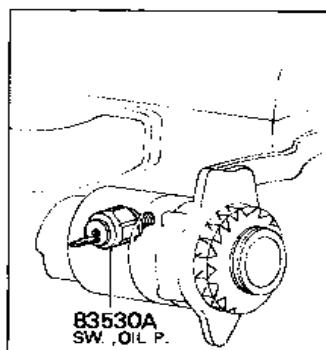
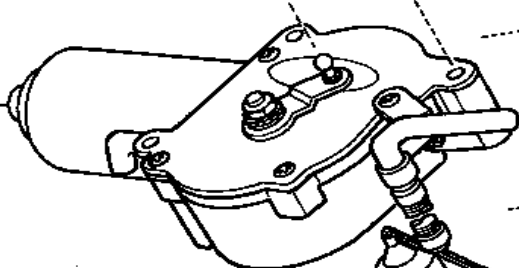

83530A
SW, OIL P.

91651-40814



90461-08025



28579
BRACKET

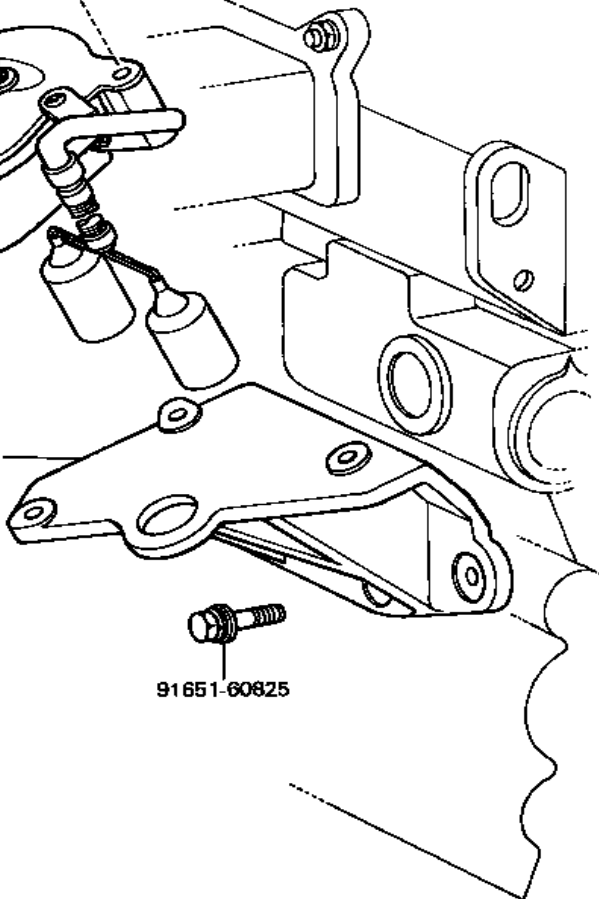

91651-60825



94180-40500



28590
RELAY, FUEL C.

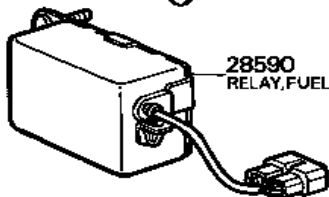

テール ゲート レギュレータ モータ
Tail Gate Regulator Motor

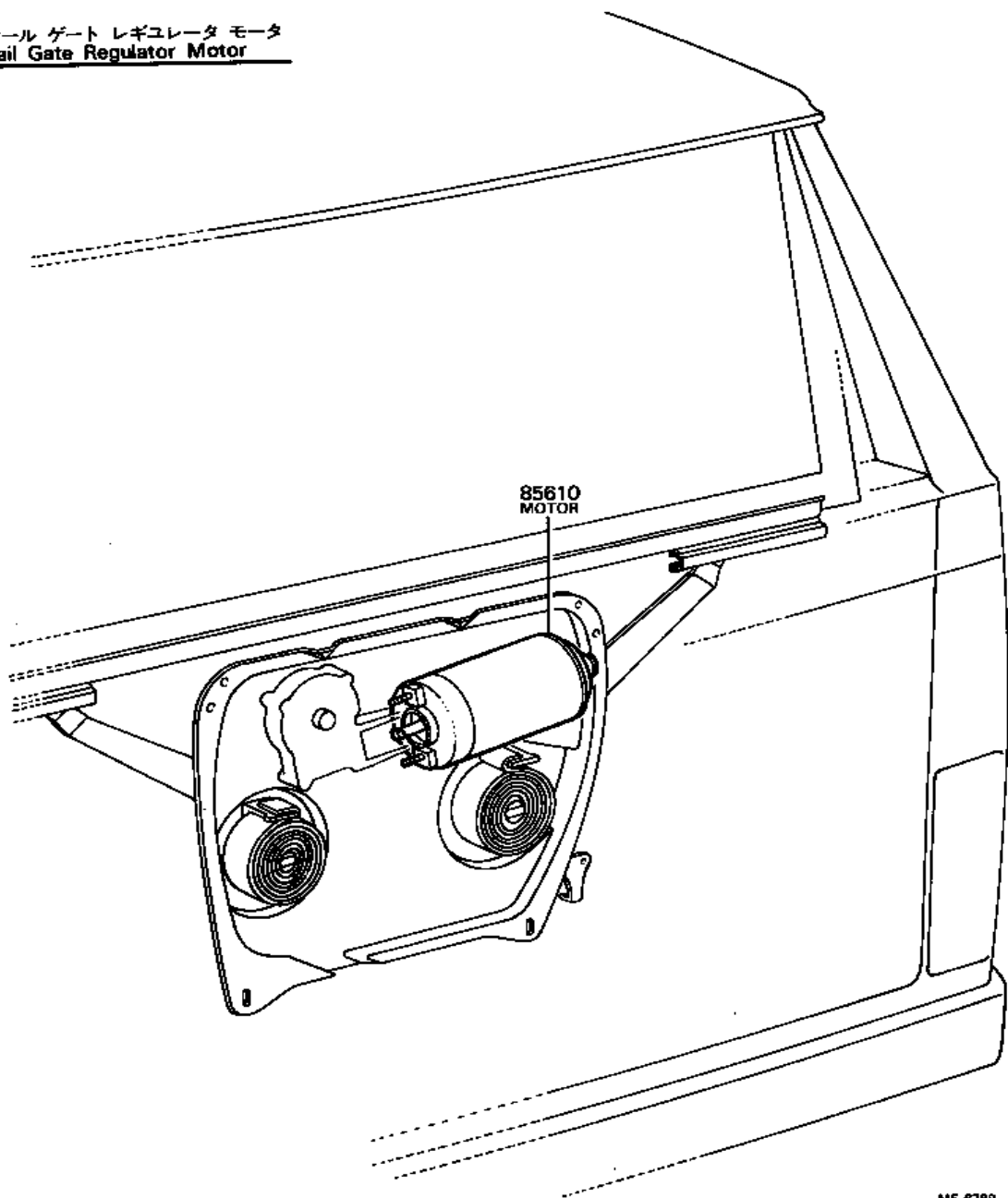

86012
PART SET RADIO

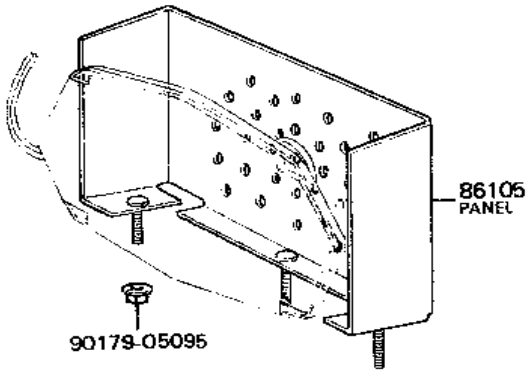
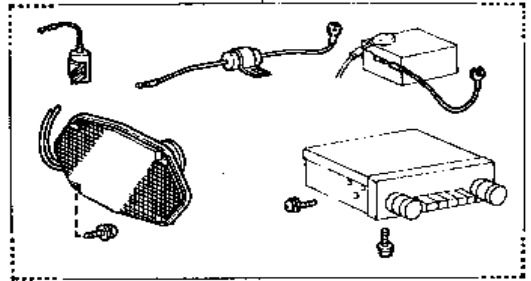

(7501-) 12V System

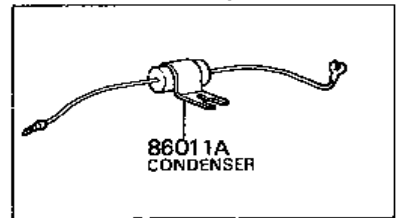

86011
RADIO & SETTING PART SET

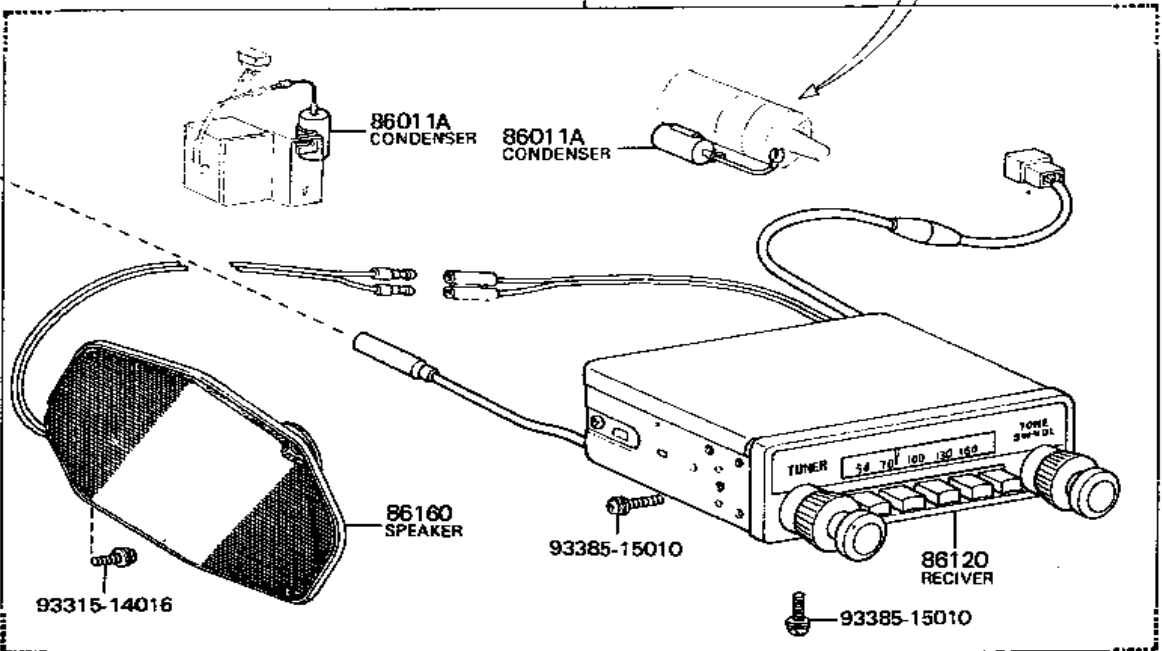

86011
RADIO & SETTING PART SET

90463-10521



90463-15067



90463-15298



90480-16008



82817-90300



90179-05095

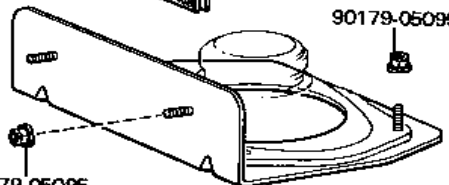

90179-05095

86161
BRACKET

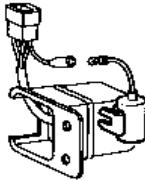

86011A
CONDENSER

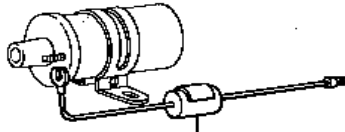

86011A
CONDENSER

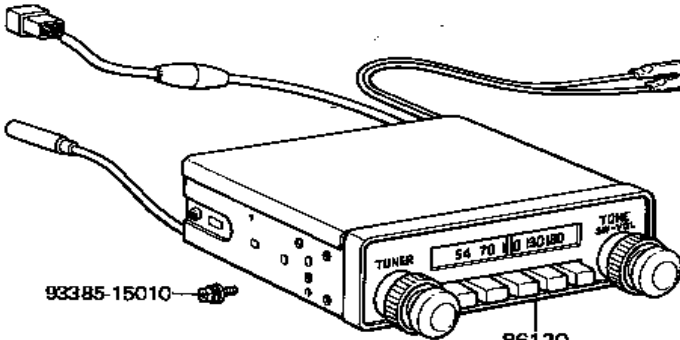

93385-15010



86120
RECEIVER

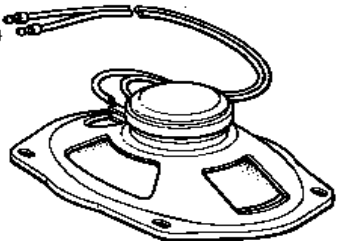

86160
SPEAKER

93385-15010



86012
PART SET, RADIO SETTING

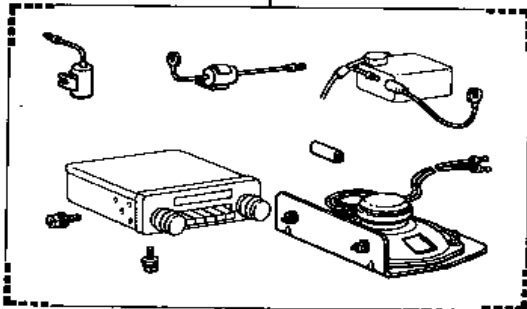

87100
HEATER & ACCESSORY

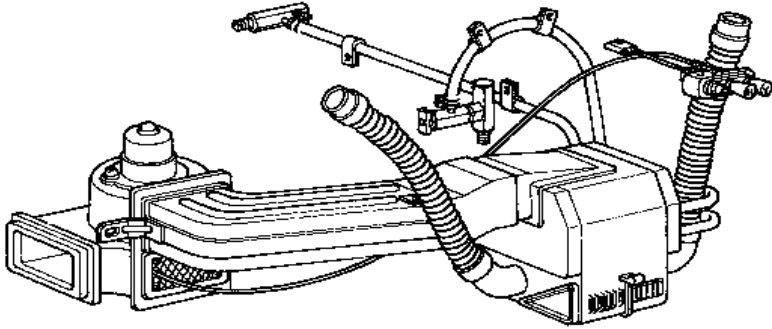

87200
HEATER & ACCESSORY

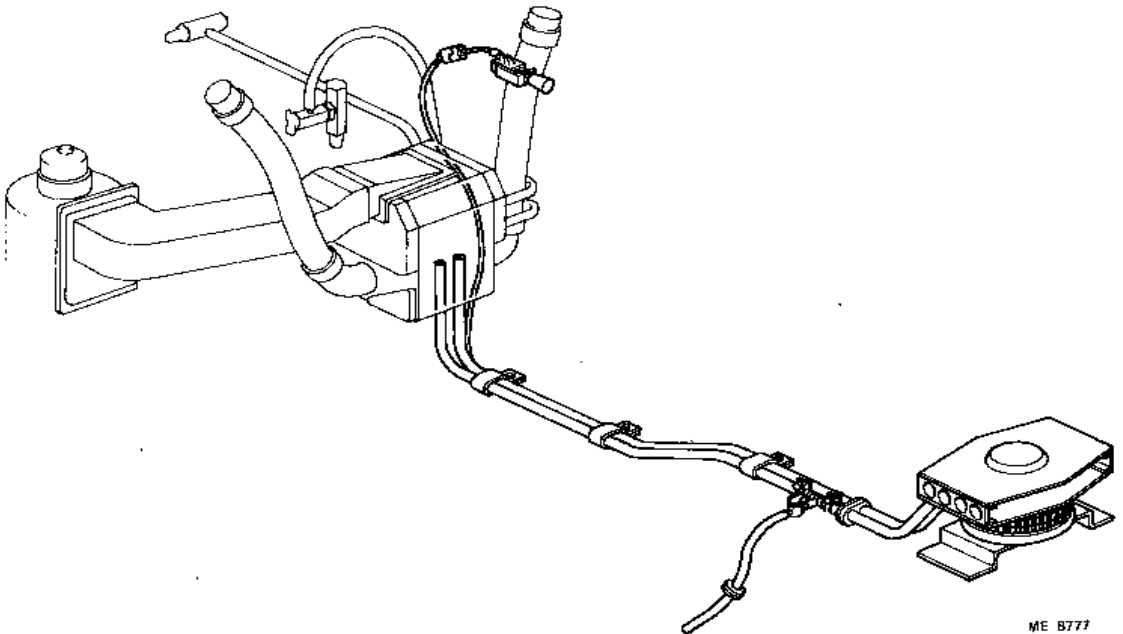

87100
HEATER & ACCESSORY ASSY

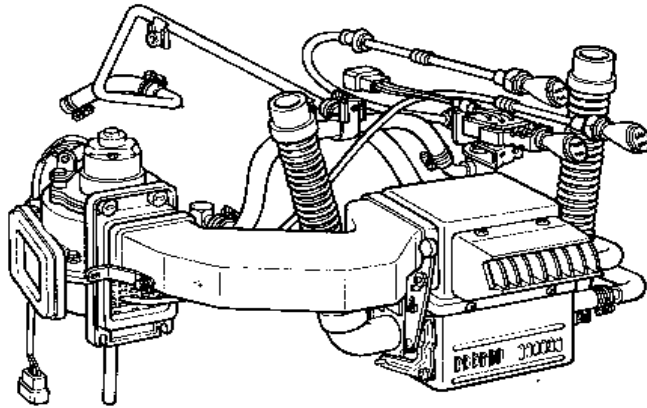

リヤヒータ付
W/Rear Heater

87100
HEATER & ACCESSORY ASSY (7309-7901)

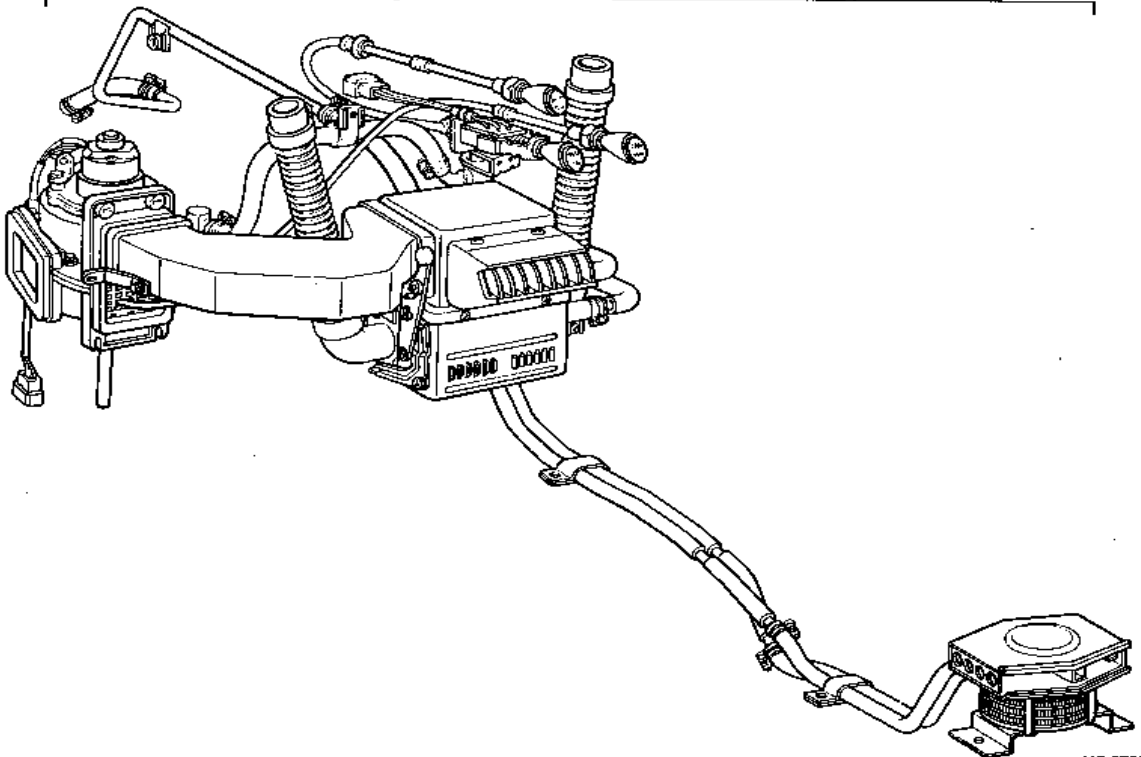

88300
COOLER & ACCESSORY

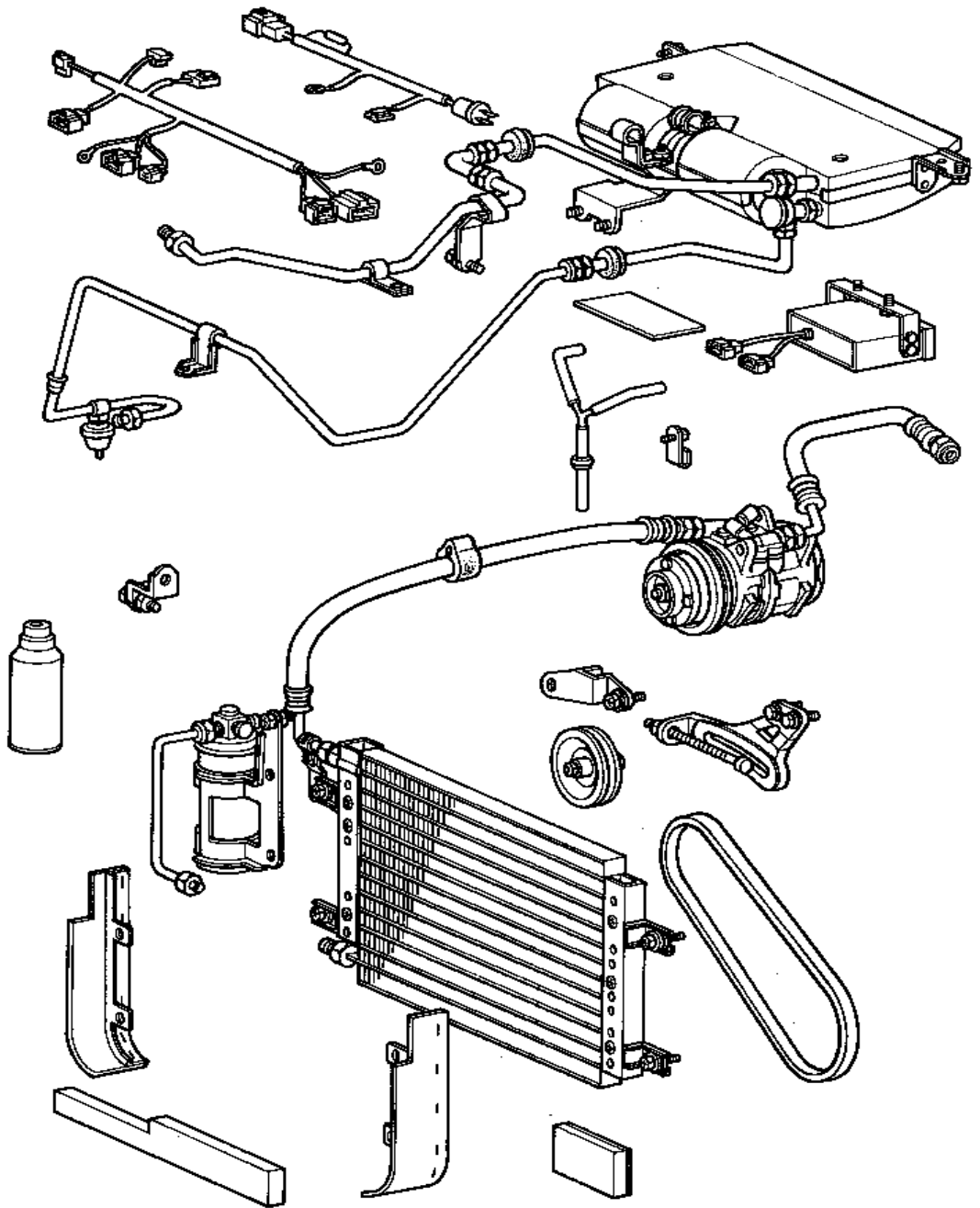

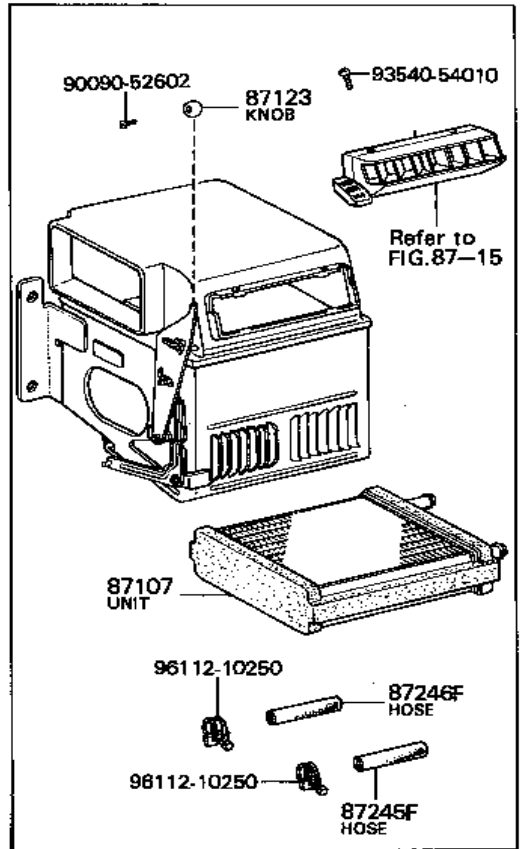
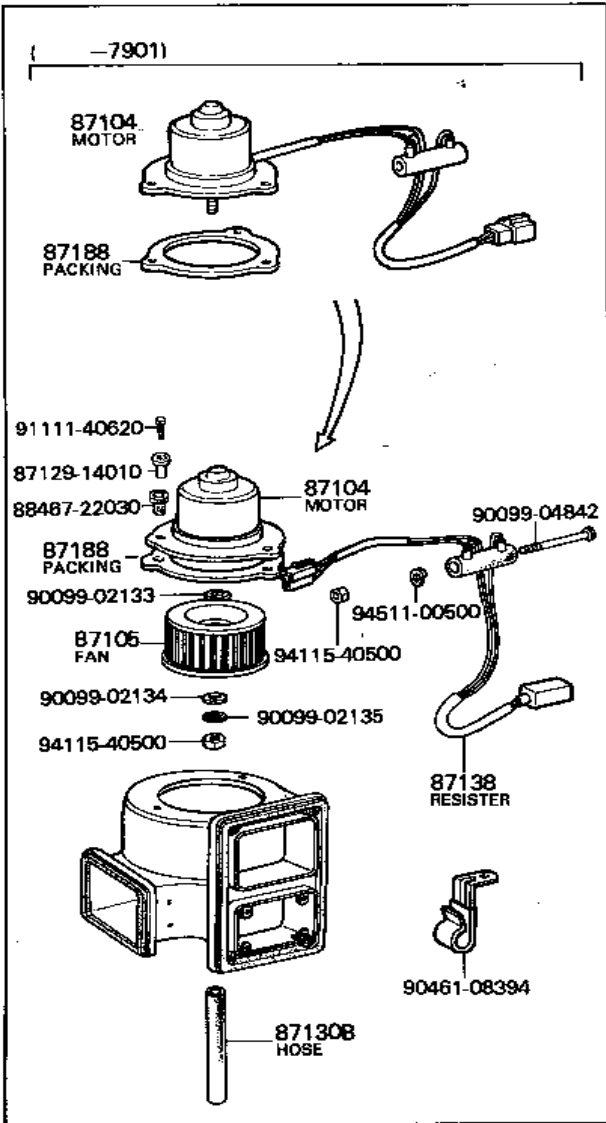
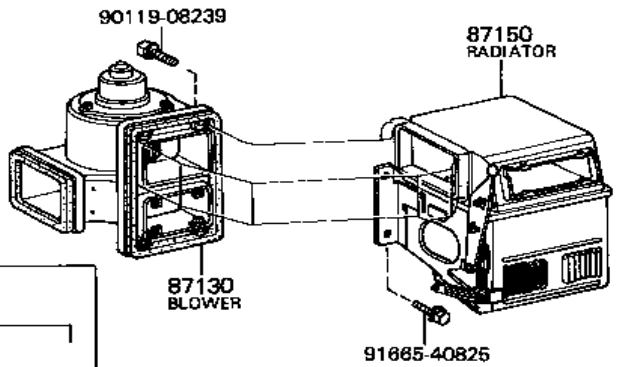

*1 FJ40,43 (6903-7607)
*2 BJ4# (7402-7607)
*3 (7607-)

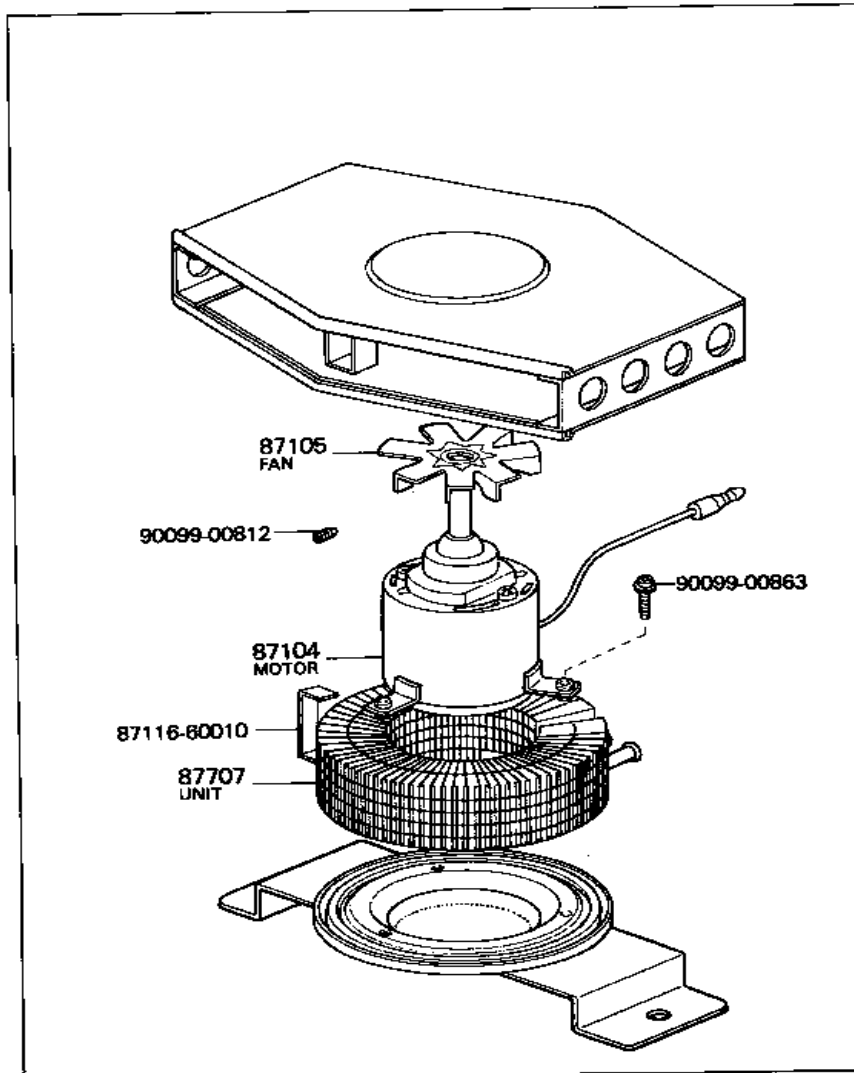
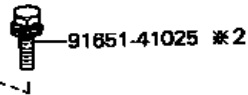
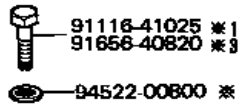
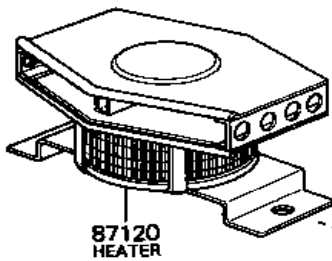

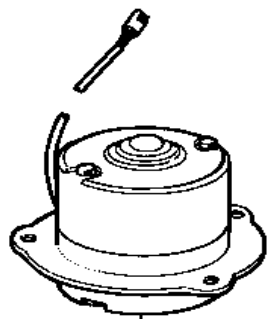

Refer to FIG. 87-12

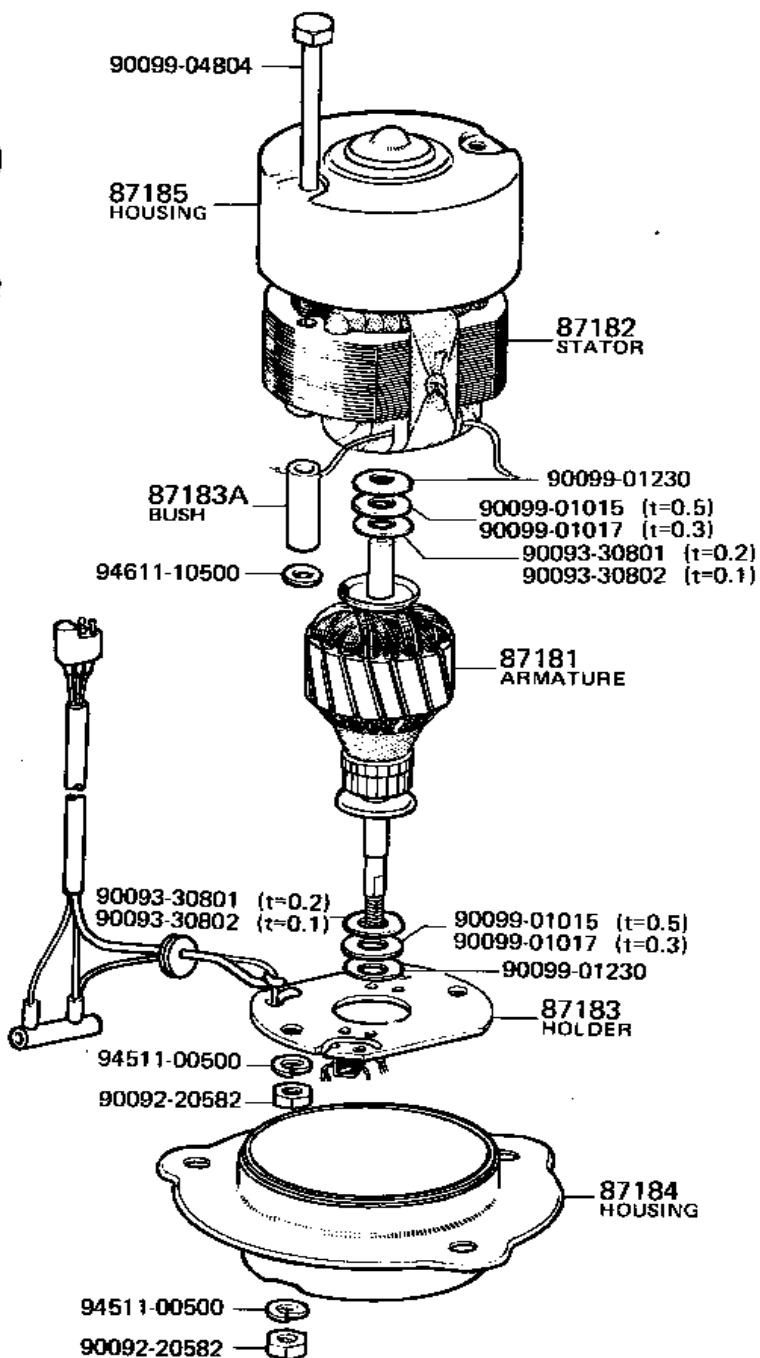

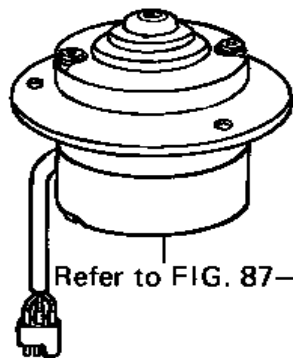

90092-20582

94511-00500

87184
HOUSING

90092-20582

94511-00500

87183
HOLDER

87183A
BUSH

94611-10500

90099-01230

90099-01015 (t=0.5)

90099-01017 (t=0.3)

90093-30801 (t=0.2)

90093-30802 (t=0.1)

90099-01230

87182
STATOR

87181
ARMATURE

90093-30801 (t=0.2)

90093-30802 (t=0.1)

90099-01015 (t=0.5)

90099-01017 (t=0.3)

90099-01230

87185
HOUSING

90099-04804

Rear Heater

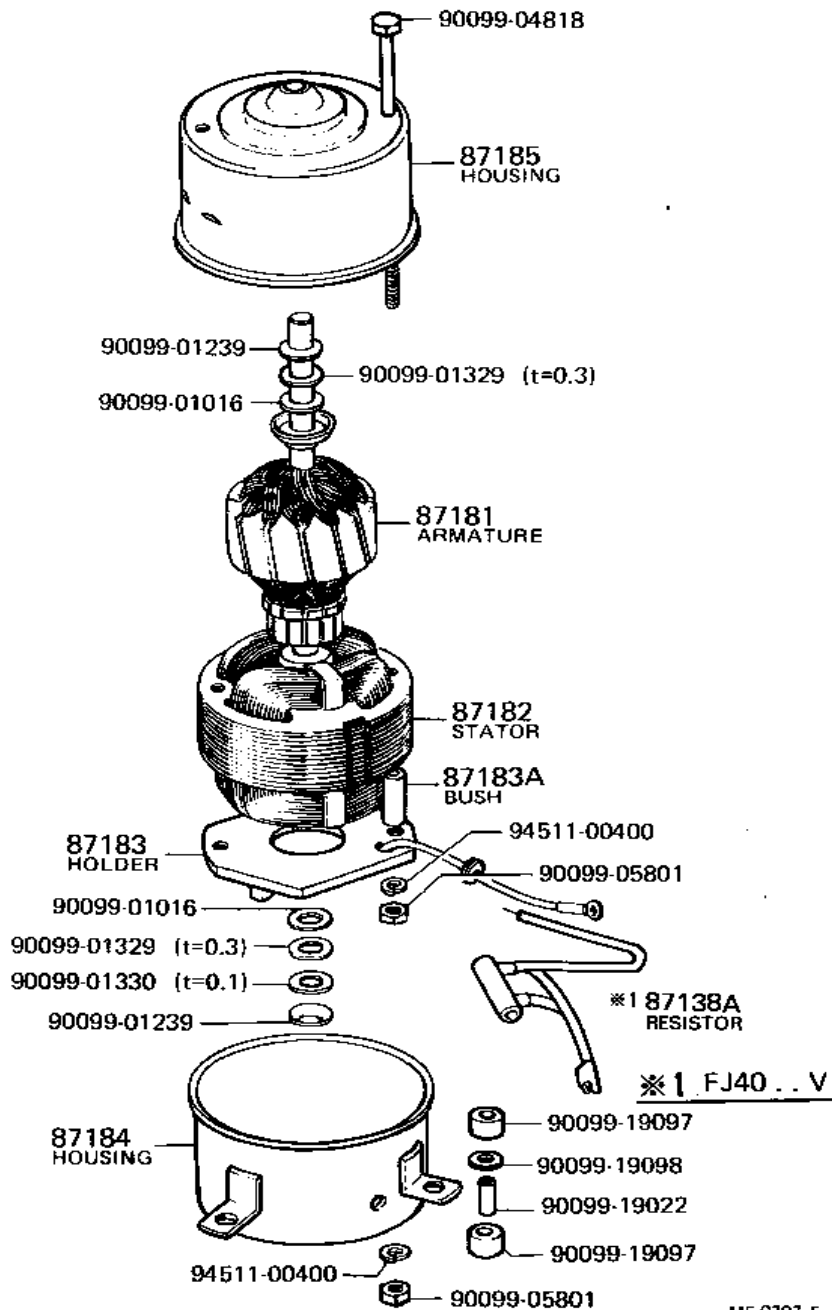
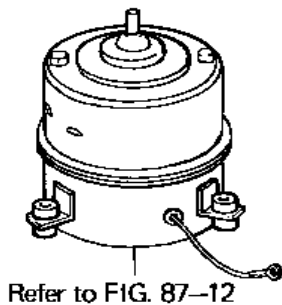

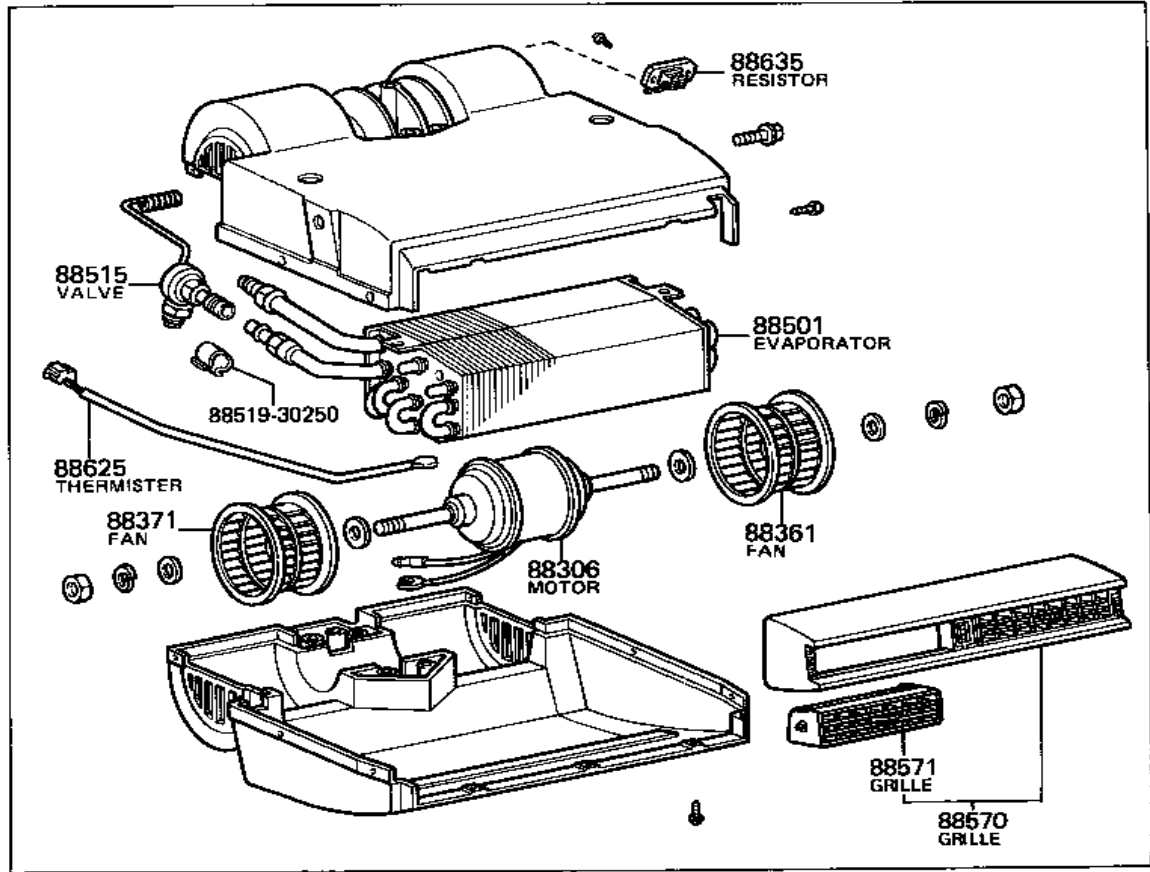
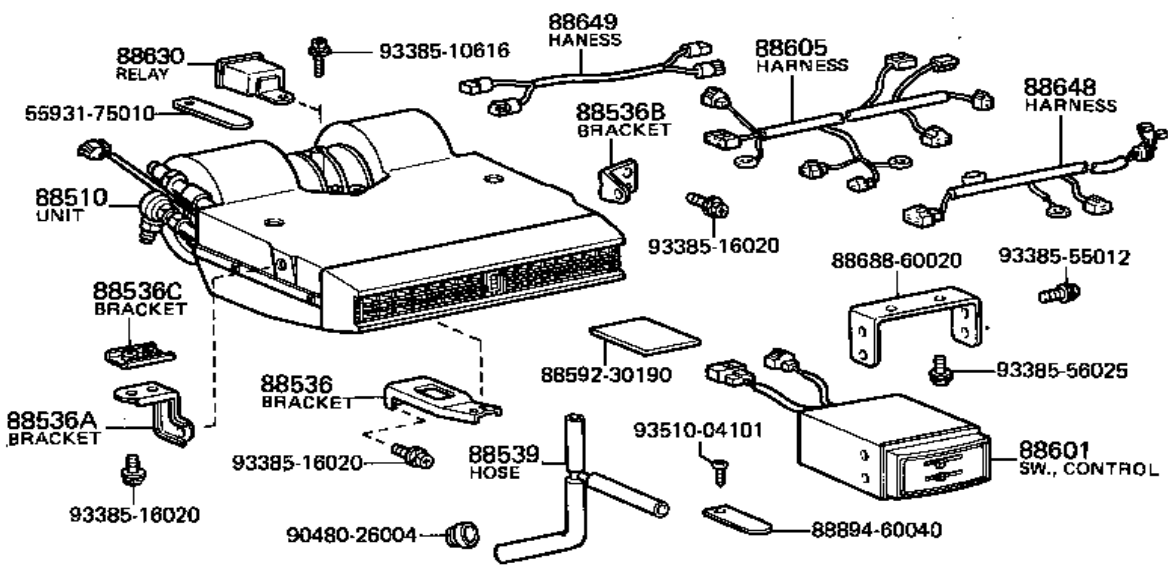

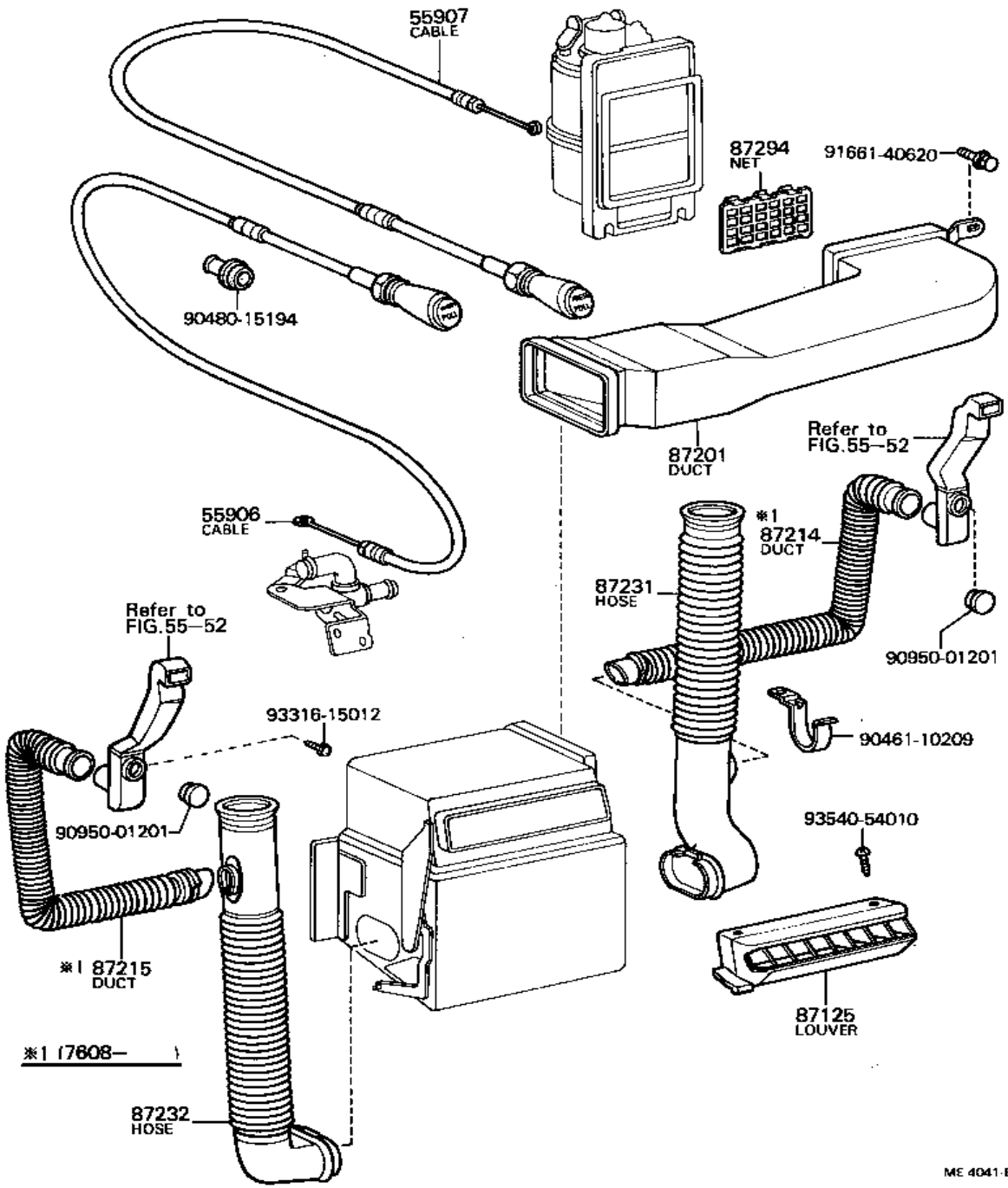

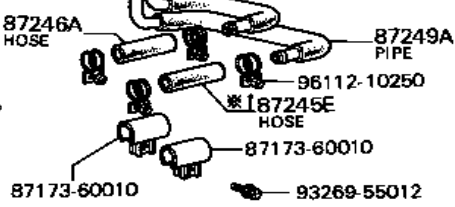
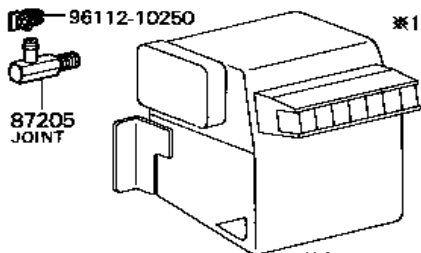
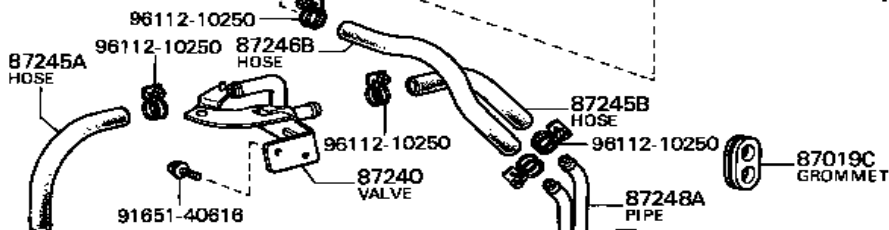
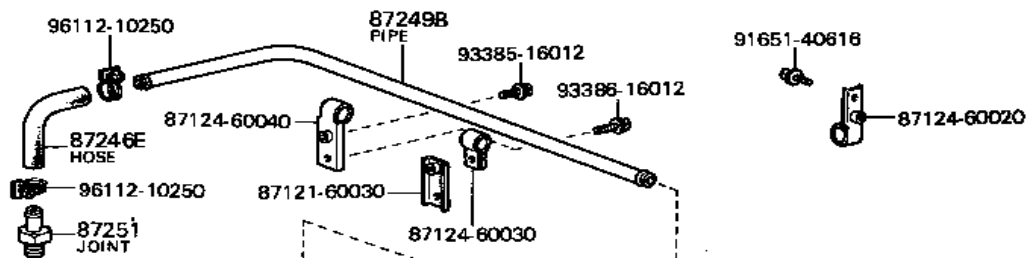

*1 右ハンドル RHD (7402-7509)

リヤヒータ
Rear Heater

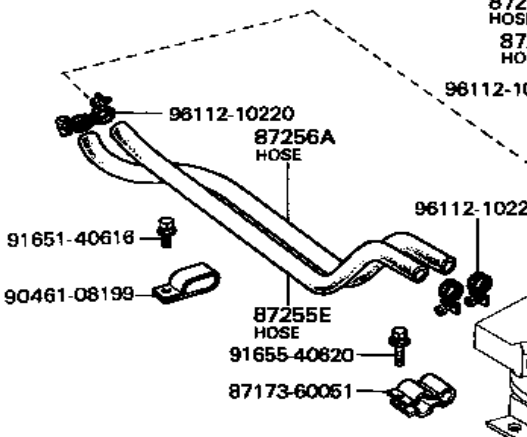
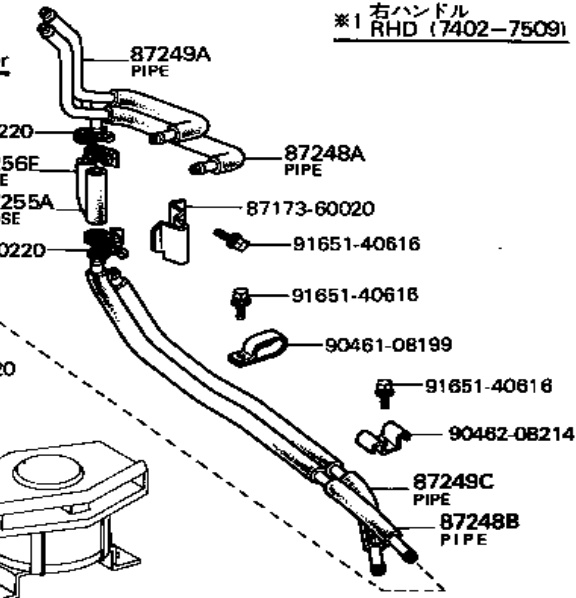

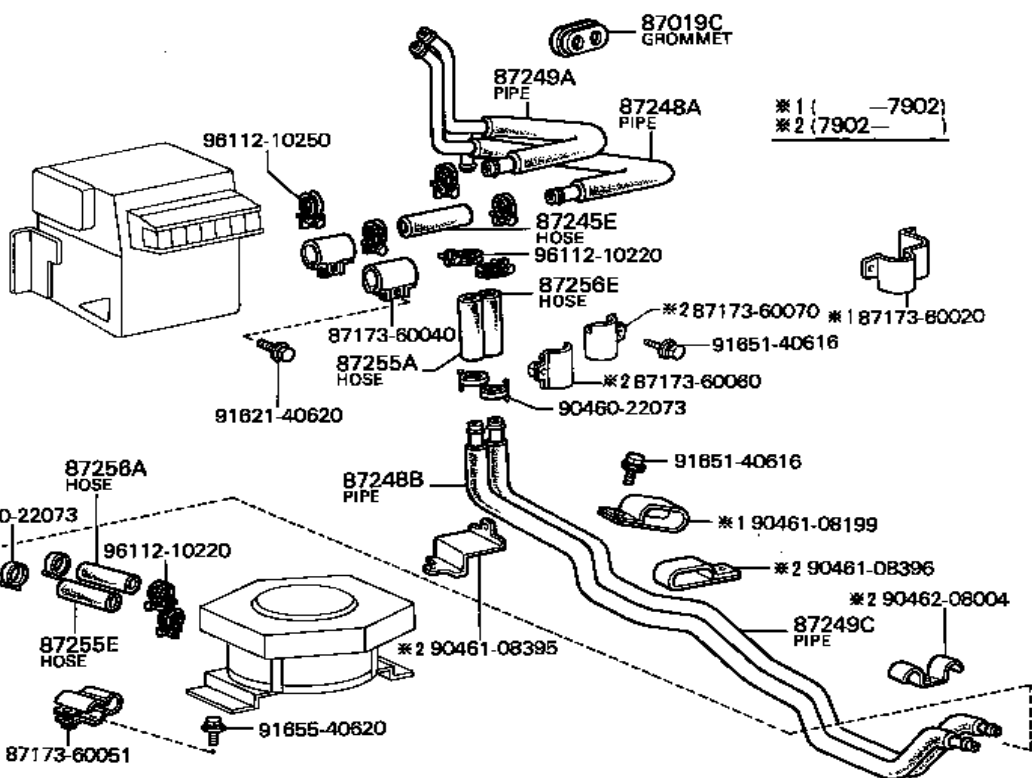
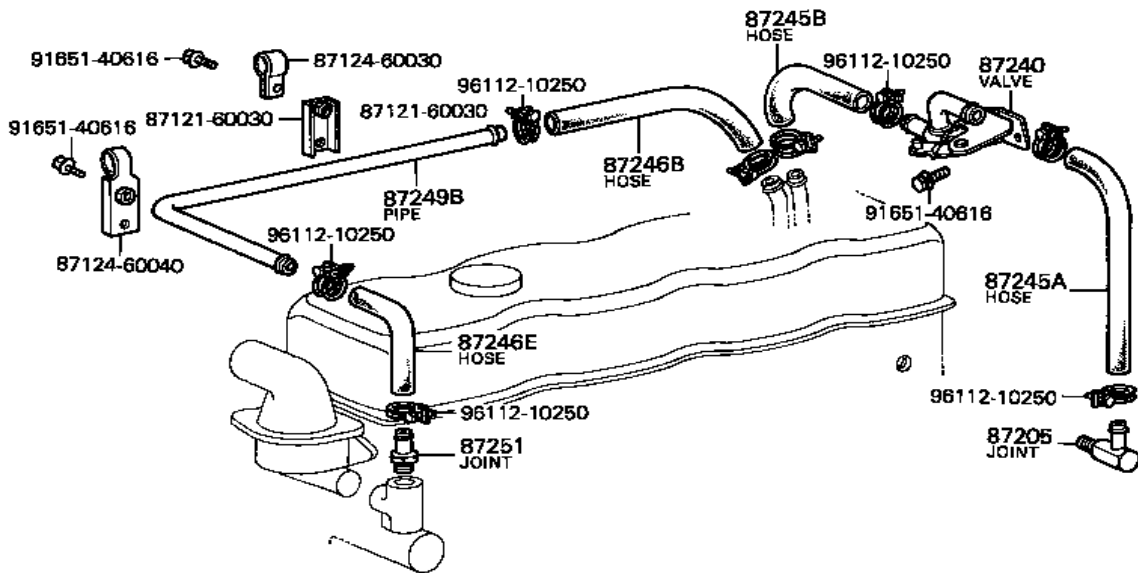

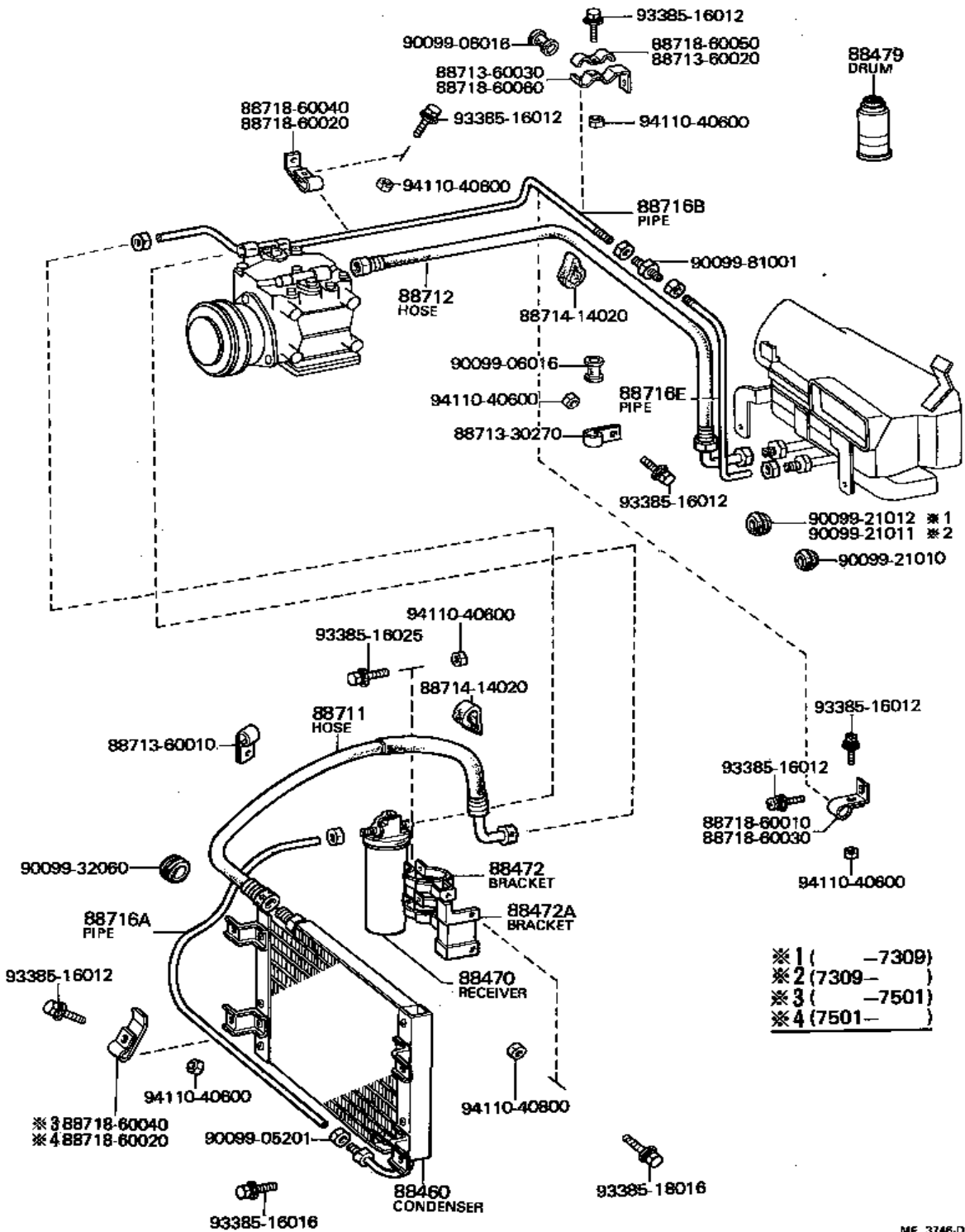

- *1 (-7309)
- *2 (7309 -)
- *3 (-7501)
- *4 (7501 -)

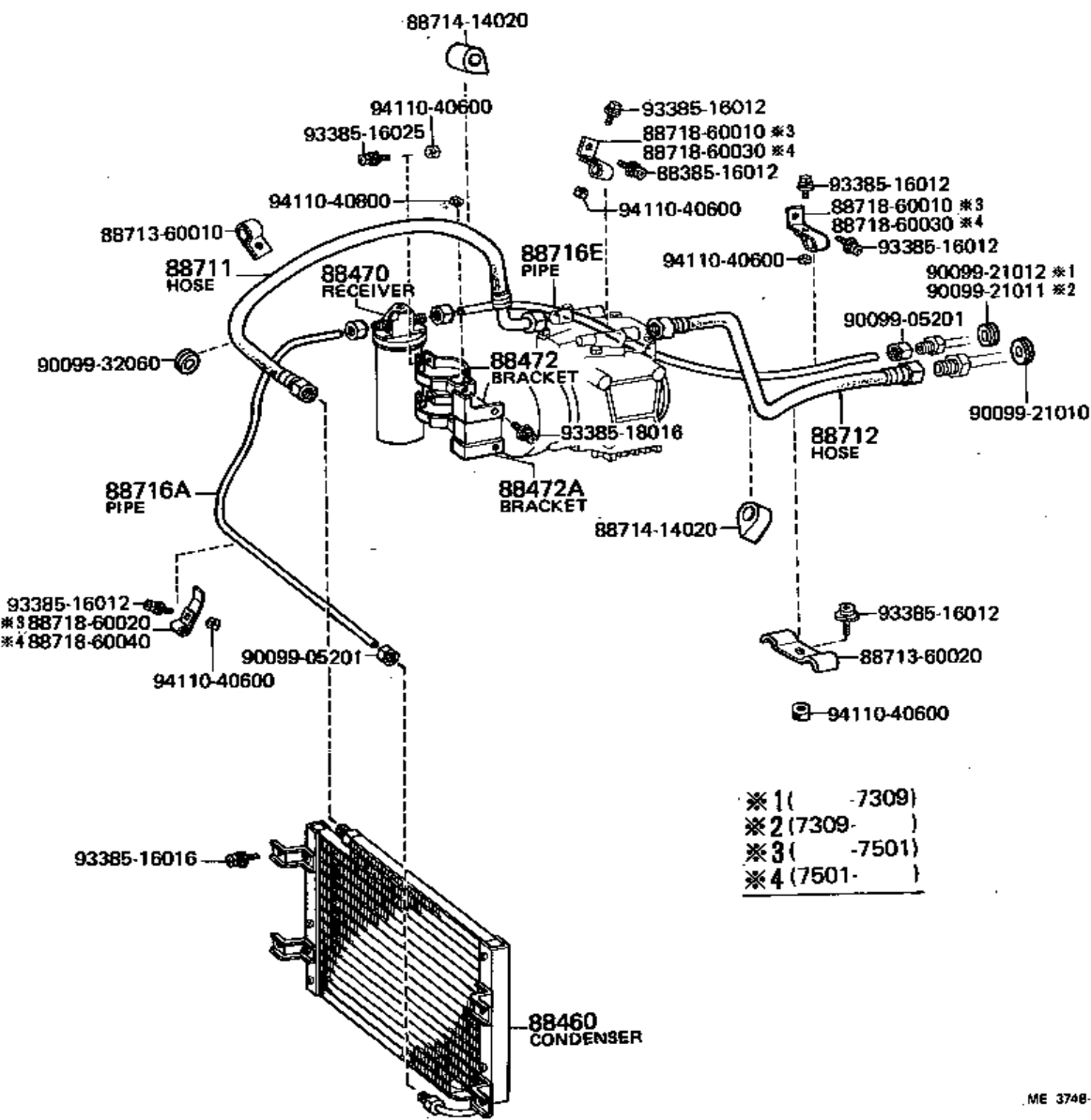

- *1 (-7309)
- *2 (7309-)
- *3 (-7501)
- *4 (7501-)

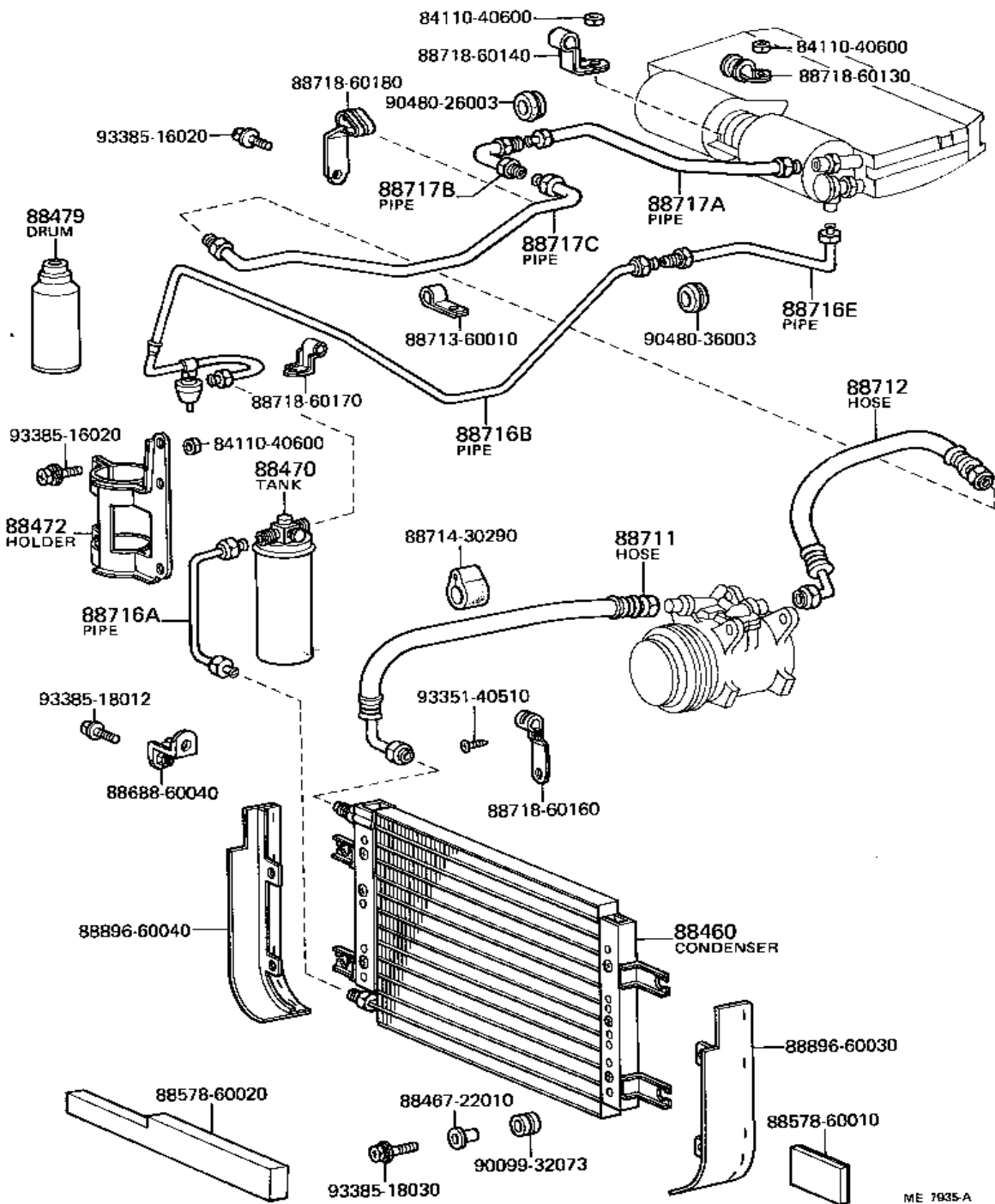

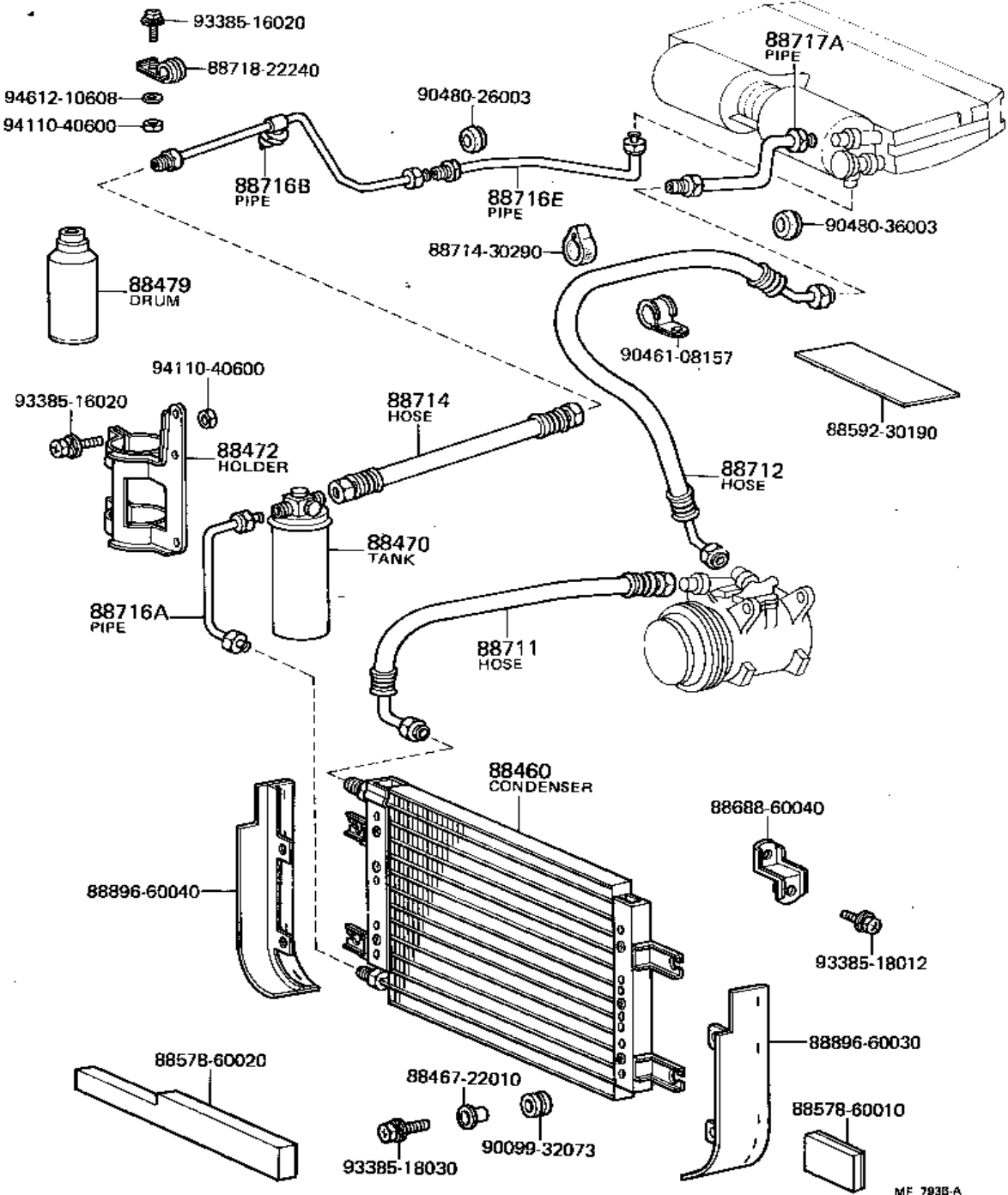

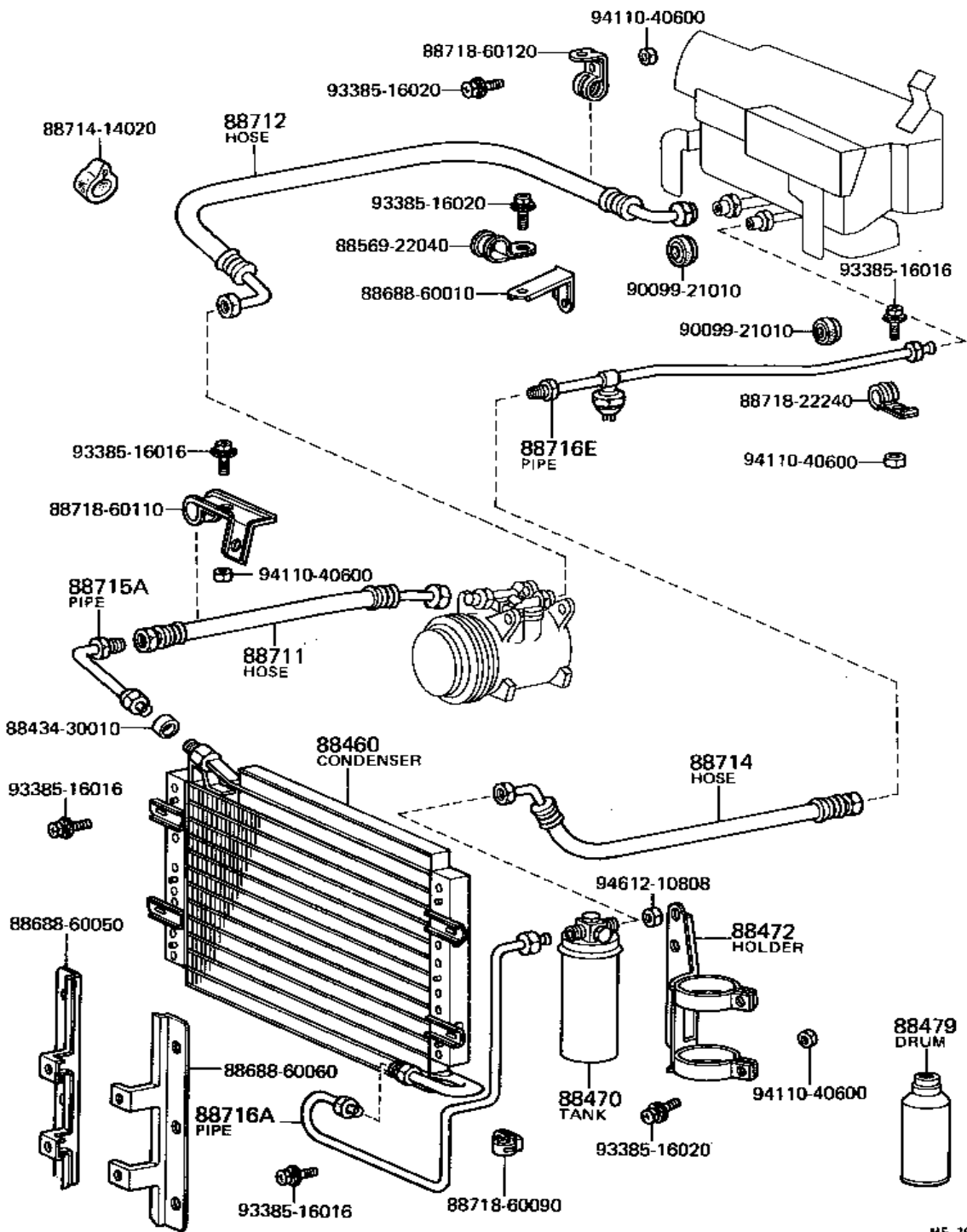

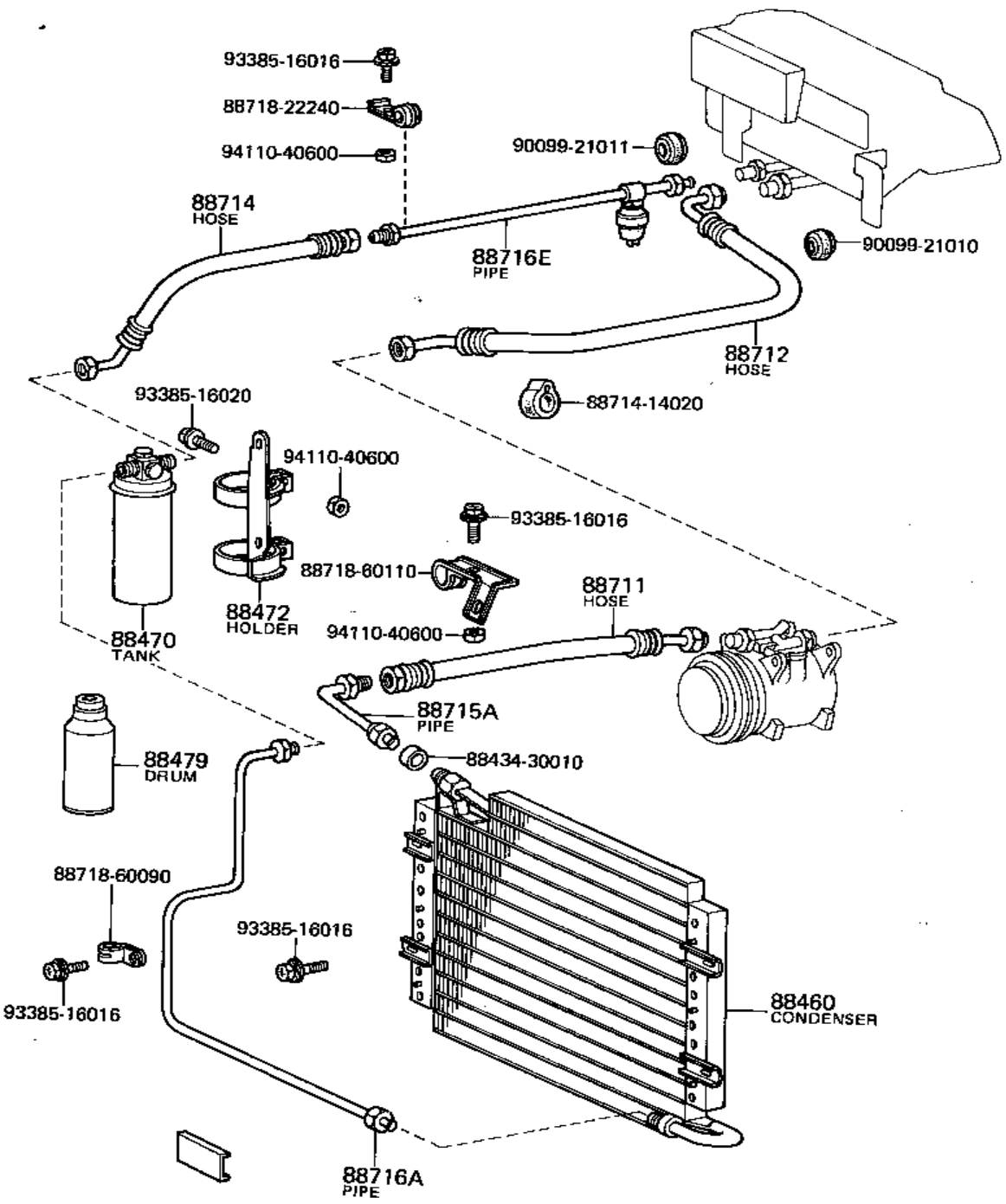

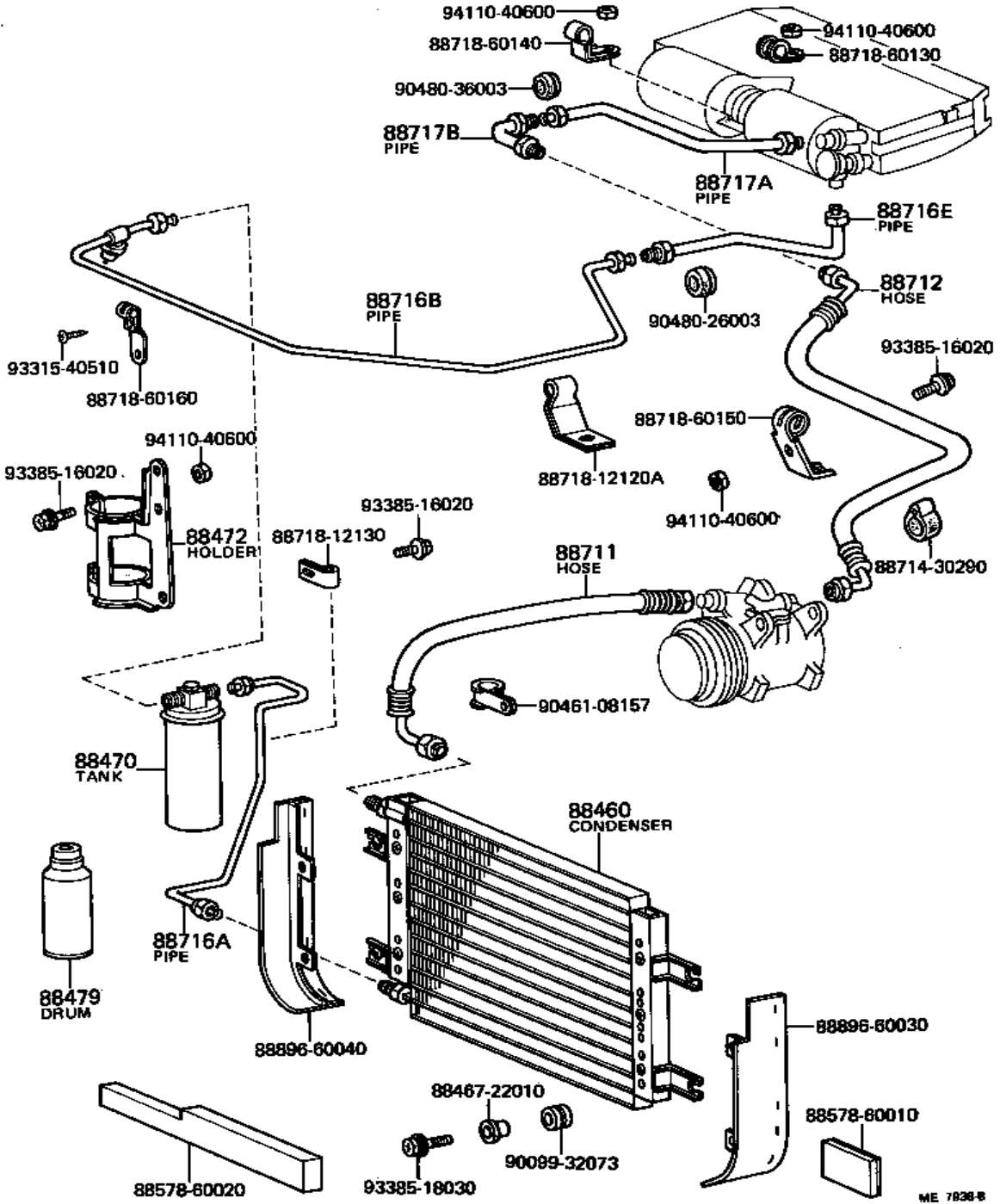

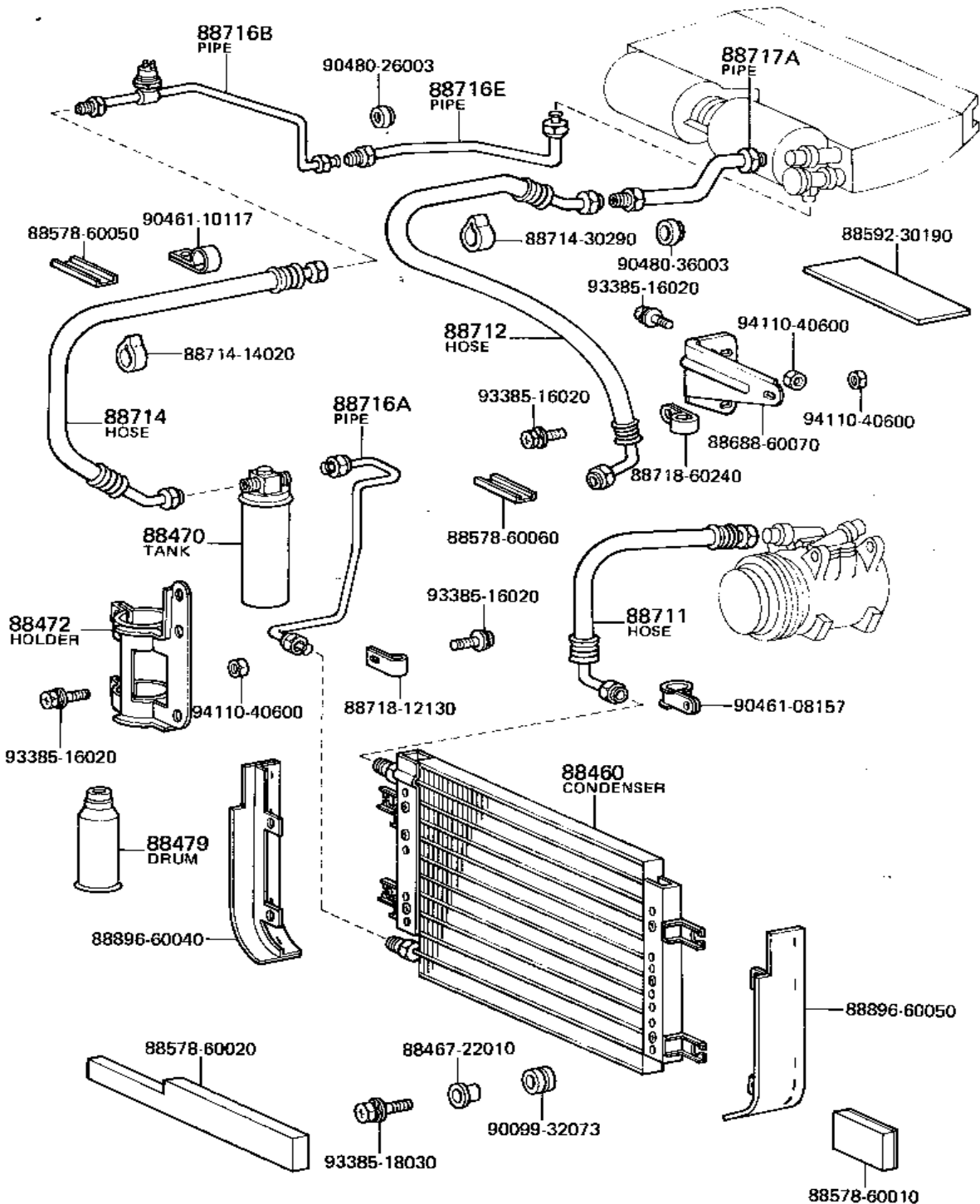

FJ55 . . LHD

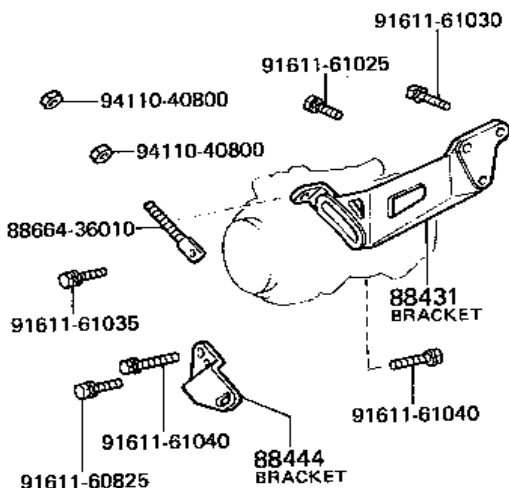

FJ55 . . RHD

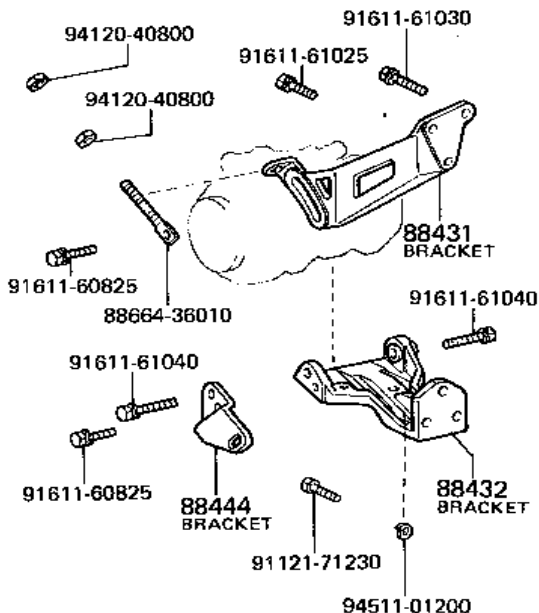

FJ4#

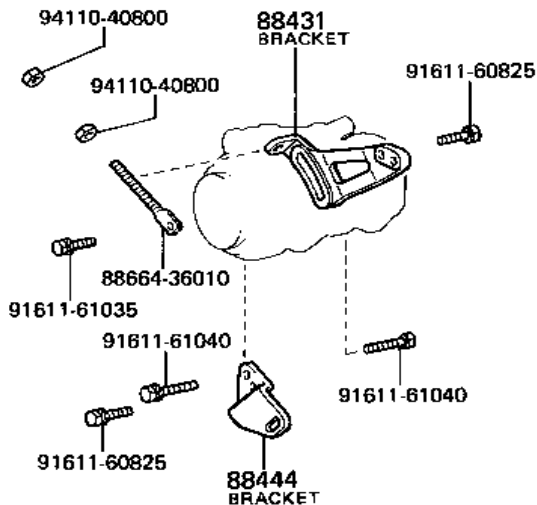

BJ40

